

SK210D Dismantling Machine

Precision dismantling increases the value of end-of-life vehicle resources

The Evolution of the Asian car dismantling industry by Kobelco

Four times* the vehicle dismantling capability compared with hand dismantling.













*In one day (Kobelco test figures)

15 vehicles > 
One operative working by hand.  

60 vehicles > 
One operative in a Kobelco Car Dismantling machine.  



The machine's special attachment is designed to strip materials from End-of-Life Vehicles (ELV) safely and thoroughly

Engine 	Catalytic converters 	Body Steel 	Seats 	Windows 
Suspension 	Radiator 	Brakes 	Front & Rear Bumpers 	Transmission 
Doors 	Harnesses 	Wheels/Tires 		

Machine designed and built specifically for car dismantling

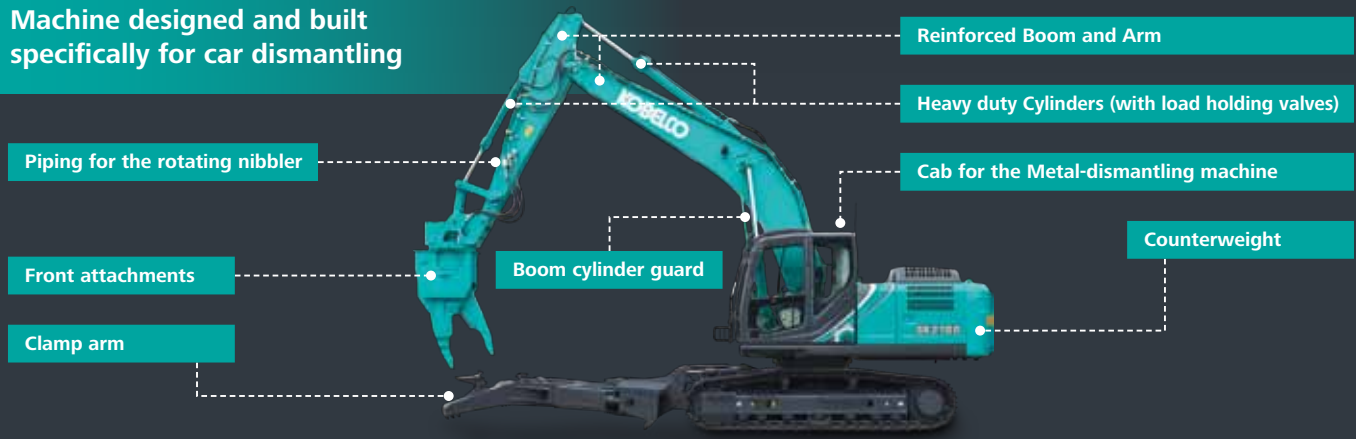

This catalog may contain photographs of machines with specifications that differ from of machines sold in your areas. Please consult your nearest KOBELCO distributor.

DIMENSIONS & WORKING RANGES

Multi-dismantling machine

Unit : mm

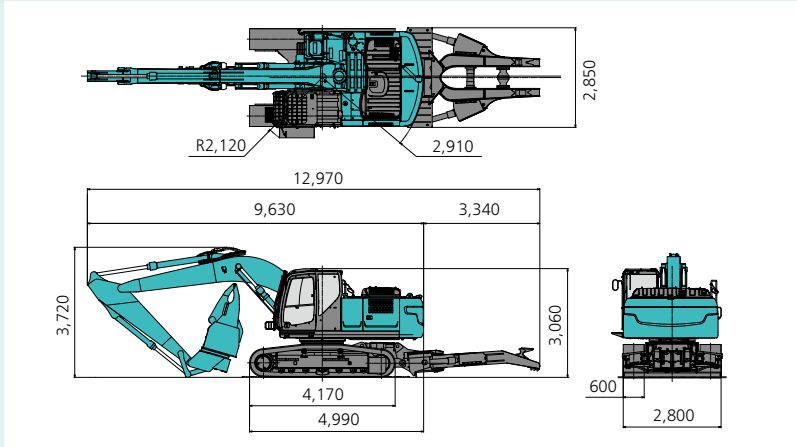

Multi-dismantling machine

Unit : mm

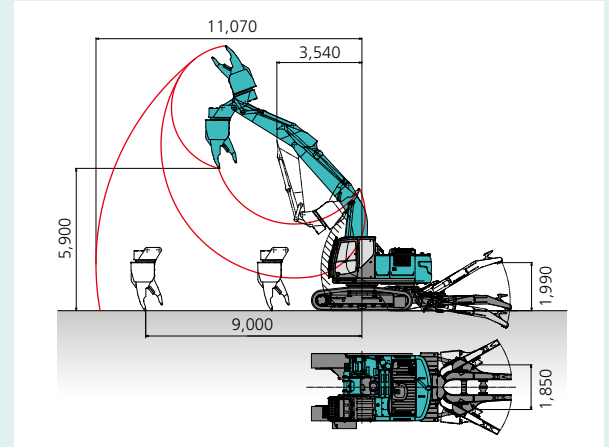

Vehicle dismantling machine

Unit : mm

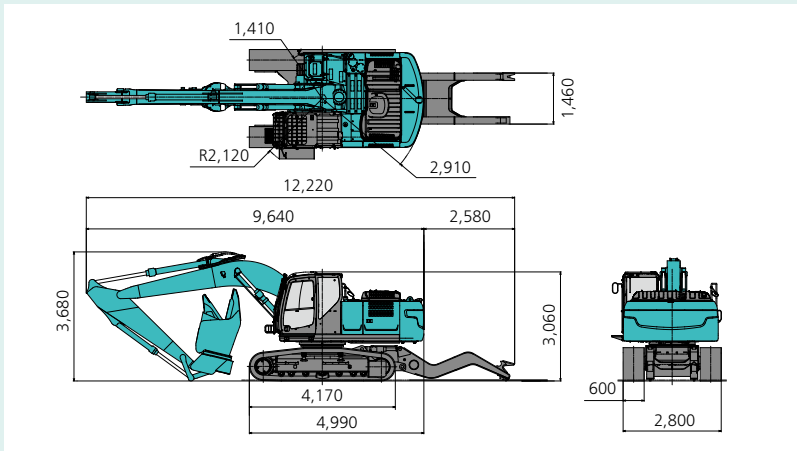

Vehicle dismantling machine

Unit : mm

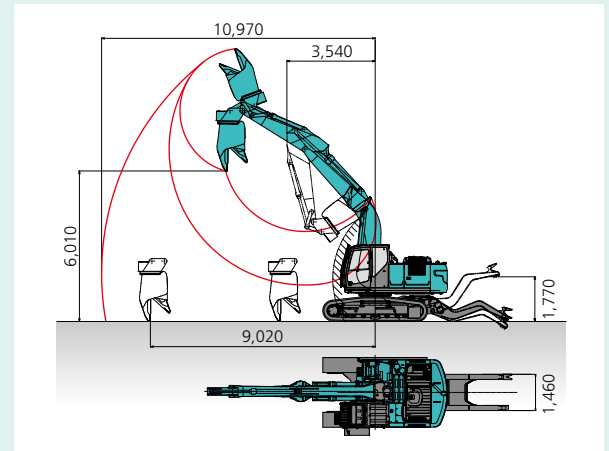

SPECIFICATIONS

Model	SK210D-10	
	Vehicle dismantling machine KV800PR	Multi-use dismantling machine KVE720PR
Type		
Weight		
Operating mass	26,800kg	29,700kg
Engine	HINO J05ETA-KSSE	
Model	HINO J05ETA-KSSE	
Type	Four-cycle liquid-cooled direct injection diesel turbo charger with intercooler	
Rated output power	114 kW/2,000 min ⁻¹ (ISO 9249 : with fan) 118 kW/2,000 min ⁻¹ (ISO 14396 : without fan)	
Fuel tank	320L	
Front Attachments		
Shearing force (blade center)	882kN	539kN
Crushing force (tooth-jaw tip)	372kN	196kN
Travel system		
Travel speed	1st 3.6 km/h 2nd 6.0 km/h	
Hydraulic system		
Hydraulic pump Type	Double variable displacement axial piston pumps with a gear pump	
Max. discharge flow	2 x 220 L/min, 1 x 20 L/min	

EQUIPMENT

STANDARD EQUIPMENT

- Clamp arm(Vehicle dismantling), Open/close type clamp arms(Multi-dismantling)
- Nibbler KV800PR(Vehicle dismantling), Nibbler KVE720PR(Multi-dismantling)
- Standard cab
- Tinted safety glass and shatterproof film
- Front window guard(wire mesh guard)
- Cab interference prevention system
- 7-way adjustable suspension seat with head rest
- Cab with two lights
- Boom with two lights
- HD boom
- HD arm
- Boom cylinder guards
- Dismantling arm cylinder
- Dismantling bucket cylinder
- Upper frame under cover guards
- Swivel guard
- 600mm Track shoes
- One way call

OPTIONAL EQUIPMENT

- Nibbler KVE720PR(Vehicle dismantling), Nibbler KV800PR(Multi-dismantling)
- Front guard (bar style guard)
- Polycarbonate guard
- Top guard
- 600mm Flat shoes
- Eagle-eye view
- Two Hand Control Proportional levers, pilot-operated

Note: This catalog may contain photographs of machines with specifications that differ from of machines sold in your areas.

Please consult your nearest KOBELCO distributor.

Specialist equipment is needed to use this machine in demolition work. Before using it please contact your KOBELCO dealer.

Due to our policy of continuous product improvements all designs and specifications are subject to change without advance notice.

Copyright by **KOBELCO CONSTRUCTION MACHINERY CO., LTD.** No part of this catalog may be reproduced in any manner without notice.

KOBELCO CONSTRUCTION MACHINERY CO., LTD.

5-15, Kitashinagawa 5-chome, Shinagawa-ku, Tokyo 141-8626 JAPAN

Tel: +81 (0) 3-5789-2146 Fax: +81 (0) 3-5789-2135

<https://www.kobelcocm-global.com/>

Inquiries To: