

# ACERA GEOSPEC

Hydraulic Excavators

## SK330 SK350 LC

- Bucket Capacity:  
**1.2 –2.3 m<sup>3</sup> ISO heaped**
- Engine Power:  
**209 kW {284 PS} /2,100 min<sup>-1</sup>{rpm}**
- Operating Weight:  
**33,600 kg–SK330  
34,300 kg–SK350LC**

Complies with the latest exhaust emission regulations



US  
EPA Tier III



EU (NRMM)  
Stage IIIA



Latest Japanese  
Regulations

*That's KOBELCO!*

Your First Choice

# The Power Wave of Change



## **Announcing ACERA GEOSPEC and the Concept of Beautiful Performance.**

When we set out to design our new hydraulic excavators, we kept our eyes on the big picture. Of course we wanted machines with greater digging capacity. But they also had to be fuel-efficient and economical, while imposing less of a burden on the local and global environments. Applying our advanced technologies, we developed KOBELCO's new ACERA GEOSPEC series, an entirely new kind of excavator that beautifully balances all the demands of today's construction industry. Lean and efficient with capacity to spare, these sleek powerhouses bring a whole new style to the worksite while setting new standards for environmental responsibility.





## **NEXT-3E**



### **Pursuing the “Three E’s” The Perfection of Next-Generation, Network Performance**

#### **Enhancement**

##### **Greater Performance Capacity**

- New hydraulic circuitry minimizes pressure loss
- High-efficiency, electronically controlled Common Rail Fuel Injection Engine
- Powerful travel and arm/bucket digging force

#### **Economy**

##### **Improved Cost Efficiency**

- Advanced power plant that reduces fuel consumption
- Easy maintenance that reduces upkeep costs
- High structural durability and reliability that retain machine value longer

#### **Environment**

##### **Features That Go Easy on the Earth**

- Meets the latest exhaust emission standards
- Auto Idle Stop as standard equipment
- Noise reduction measures (with improvement of the sound quality) minimize noise and vibration

#### **ACERA GEOSPEC ACERA GEOSPEC**

The “GEO” in GEOSPEC expresses our deep respect for our planet, and for the solid ground where excavators are in their element. This is accompanied by SPEC, which refers to the performance specifications needed to get the job done efficiently as we carry on the tradition of the urban-friendly ACERA series.

The GEOSPEC Difference:

# Efficient Performance!

Amazing Productivity with a 27 % Increase in Work Volume and “Top-Class” Cost-Performance

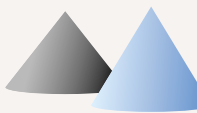

**↑ Work Volume\***  
**27 %** increase in work volume using the same amount of fuel. (H-Mode)



**↓ Fuel Consumption\***  
**18 %** decrease in fuel consumption even when performing more work volume. (S-Mode)

## “Top-Class” Powerful Digging

Max. arm crowding force: **165 kN** {16.8 tf}

Max. arm crowding force with power boost: **181 kN** {18.5 tf}

Max. bucket digging force: **222 kN** {22.6 tf} **↑**

Max. bucket digging force with power boost: **244 kN** {24.9 tf} **↑**

## Powerful Travel

Travel torque: increased by **13 %** **↑**

Drawbar pulling force: **322 kN** {32.8 tf} **↑**

## Greater Swing Power, Shorter Cycle Times

Swing torque: increased by **7 %** **↑**

Swing speed: **16 %** **↑**  
 faster (10.0 min<sup>-1</sup>)

## Significant Extension of Continuous Working Hours

The combination of a large-capacity fuel tank and excellent fuel efficiency delivers an impressive 22% increase in continuous operation hours.\*\*



Fuel tank:  
**580L**  
**22 %** **↑**

## Light Lever Operation

It takes 10% less effort to move the control levers, so that operators can work longer hours with less fatigue.

**10 %**  
**Less**



## NEXT-3E Technology New Hydraulic System



Rigorous inspections for pressure loss are performed on all components of the hydraulic piping, from the first spool of the control valve to the connectors. This regimen, combined with the use of a new, high-efficiency pump, cuts energy loss to a minimum.

\*The value shows results from actual measurements taken by KOBELCO when compared with previous KOBELCO models.

\*\*The value shows results from actual measurements taken by KOBELCO for continuous operation in S Mode, compared with previous models. Results vary depending on the method of operation and load conditions.



**NEXT-3E Technology  
Next-Generation Electronic Engine Control**

The high-pressure, common-rail fuel-injection engine features a cooled EGR (Exhaust Gas Recirculation) device that lowers the air intake temperature to keep the oxygen concentration down. The multiple injection system features adjustable control to maximize fuel efficiency and provide powerful medium/low-speed torque. The result is a highly fuel-efficient engine that greatly reduces emissions of PM (particulate matter) and NOx into the atmosphere.

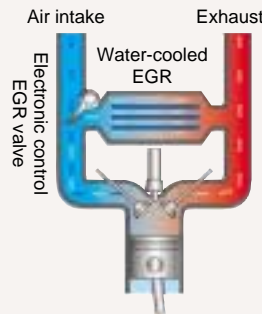

**Simple Select:  
Two Digging Modes**



- H** For heavy duty when a higher performance level is required.  
**H-Mode**
- S** For normal operations with lower fuel consumption.  
**S-Mode**

**Optional N&B (crusher and breaker)**

The operator selects the desired mode from inside the cab, and the selector valve automatically configures the machine accordingly.

**Attachment Mode Selector Switch**

**NEW!**

There's a choice of three different hydraulic circuits, to accommodate bucket, crusher or breaker, and the desired attachment mode can be selected with a switch, which automatically configures the selector valve. All attachment modes can be used in either S-mode or H-mode.



**Seamless, Smooth Combined Operations**

The GEOSPEC machines have inherited the various systems that make inching and combined operations easy and accurate, with further refinements that make a good thing even better. Leveling and other combined operations can be carried out with graceful ease.

- Electronic Active Control System
- Arm regeneration system
- Boom lowering system
- Variable swing priority system
- Swing rebound prevention system

**NEXT-3E Technology  
Total Tuning Through Advanced ITCS Control**

The next-generation engine control is governed by a new version of ITCS, which responds quickly to sudden changes in hydraulic load to ensure that the engine runs as efficiently as possible with a minimum of wasted output.

**ITCS** (Intelligent Total Control System) is an advanced, computerized system that provides comprehensive control of all machine functions.



*The GEOSPEC Difference:*

# The Value and Quality of Sturdy Construction!

## Stable Attachment Strength

Forged and cast steel components are used throughout. The standard arm and boom also meet specifications that were classified as "reinforced" on previous KOBELCO models to ensure reliable strength.

## Emergency Acceleration (Dial) Permits Continued Operation in the Unlikely Event of Malfunction



If unexpected trouble is experienced with the ITCS mechatronic control system, the machine can still be operated using the emergency acceleration system. Digging modes are also automatically relayed to an emergency system so that digging can continue temporarily until a service person arrives to repair the primary system.

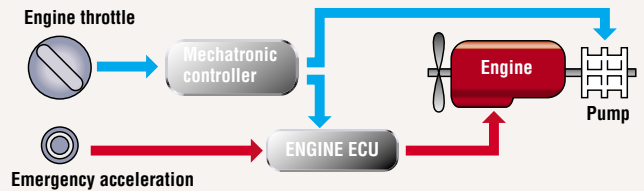

Cast steel boom foot boss

HD boom

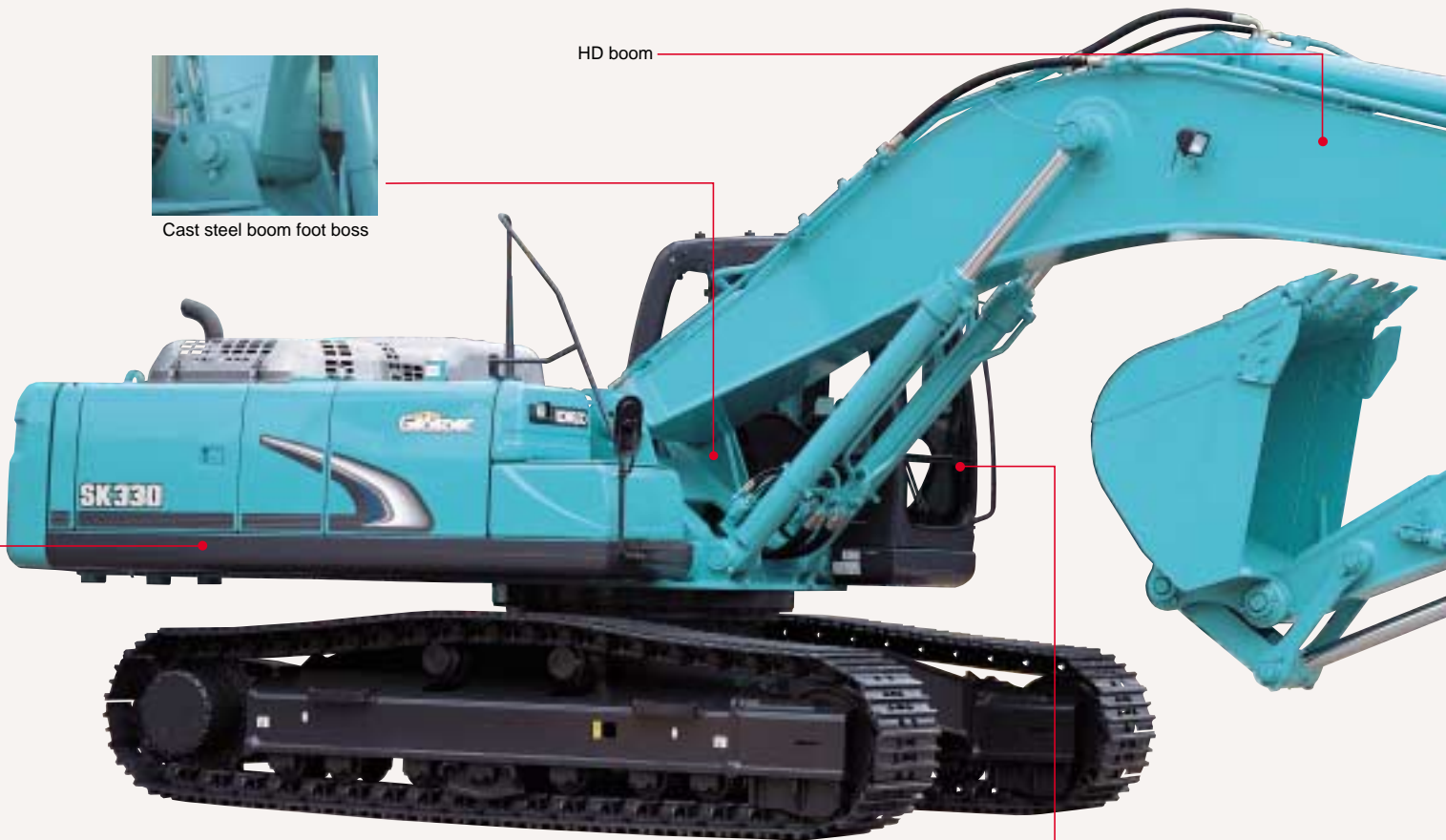

## Enhanced Upper Carbody Strength

The structure of the lower portion of the upper frame has been reassessed and the undercover area has been minimized for further strength.



## Durability That Retains Machine Value Five and Ten Years in the Future

- New operator's seat covered in durable, material
- High-quality urethane paint
- Easily repaired bolted hand rails



**The GEOSPEC Difference:  
Designed for the Environment and the Future!**

**Meets Standard Values Set by Emissions Regulations**

The engine used in the GEOSPEC machines represents the crystallization of various cutting-edge technologies that minimize the emission of PM (Particulate Matter), NOx, black smoke, and other emissions, thus meeting all internationally recognized environmental regulations, including US EPA Tier III, NRMM (Europe) Stage IIIA, and the latest Japanese regulations.

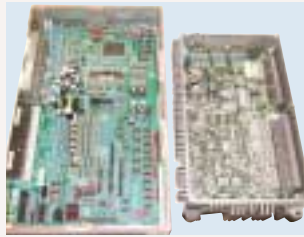

New MCU Conventional MCU

**Newly designed MCU**

- Vertical alignment and sealed cover gives better protection from water and dust
- Integration in base plate boosts assembly quality
- Reliable fixture to base plate

**Countermeasures Against Electrical System Failure**

All elements of the electrical system, including controller, have been designed for enhanced reliability.

**Large-Capacity Pump Resists Overheating**

The pump capacity has been increased by **22%** compared with previous models.

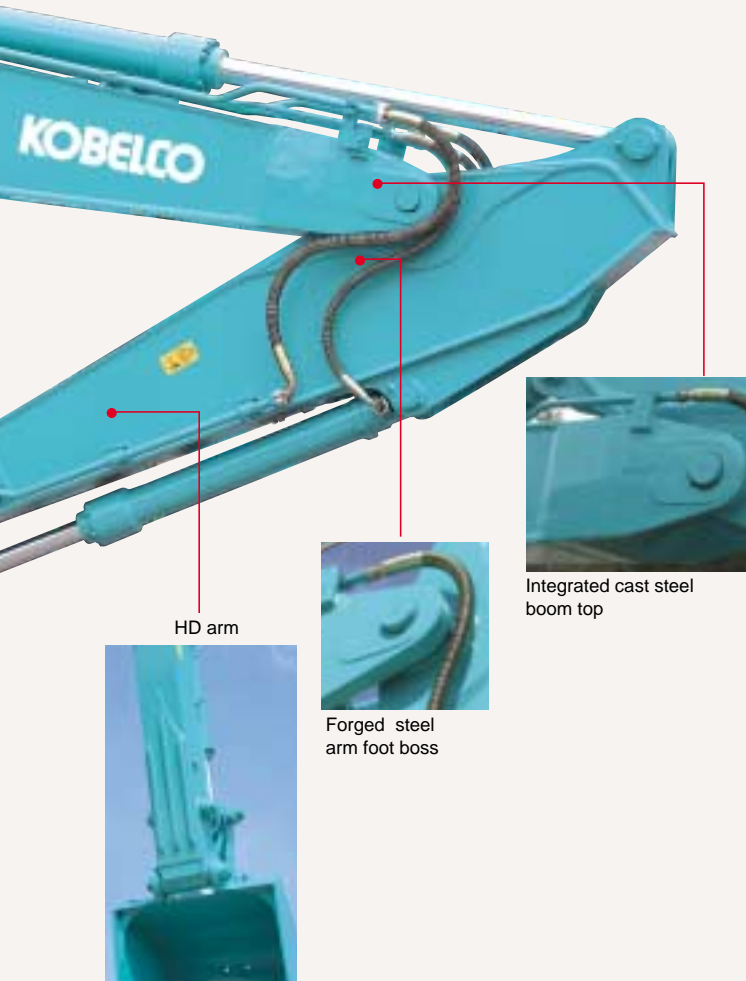

HD arm

● Reinforced arm

Integrated cast steel boom top

Forged steel arm foot boss

**Auto Idle Stop Provided as Standard Equipment**

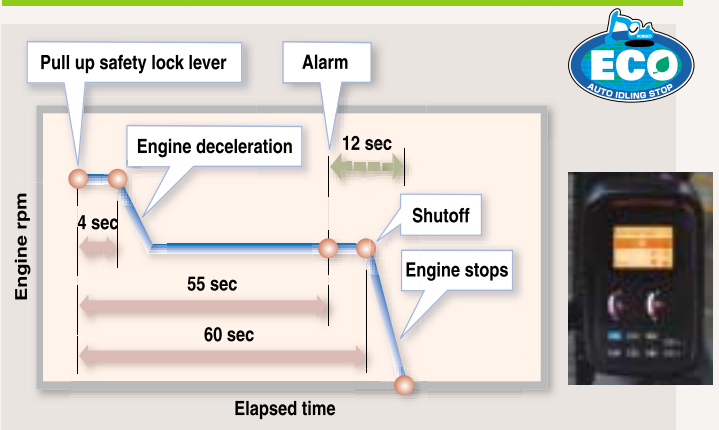

This function saves fuel and cuts emissions by shutting down the engine automatically when the machine is on stand by. It also stops the hourmeter, which helps to retain the machine's asset value.

**Automatic Acceleration/Deceleration Function Reduces Engine Speed**

Engine speed is automatically reduced when the control lever is placed in neutral, effectively saving fuel and reducing noise and exhaust emissions. The engine quickly returns to full speed when the lever is moved out of neutral.

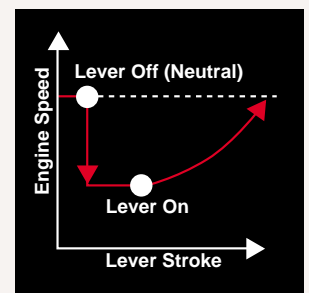

**Low Noise Level and Mild Sound Quality**

The electronically controlled common-rail engine has a unique fuel injection system that runs quietly. Also, the hydraulic pumps have been redesigned to produce a more pleasant sound during pressure relief. In short, the GEOSPEC series meets all requirements cited in latest EU stage II.

**Meets EMC (Electromagnetic Compatibility) Standards in Europe.**

Measures have been taken to ensure that the GEOSPEC machines do not cause electromagnetic interference.



## The GEOSPEC Difference:

# “On the Ground” Maintenance!

### Comfortable "On the Ground" Maintenance

The machine layout was designed with easy inspection and maintenance in mind.



Access through the right side cover

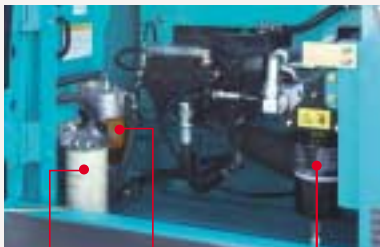

Main fuel filter  
Pre-fuel filter (with built-in water separator)  
\*Optional for NZ  
Engine Oil Filter

The fuel filter with built-in water separator functions in two ways by removing large contaminants and separating out water.

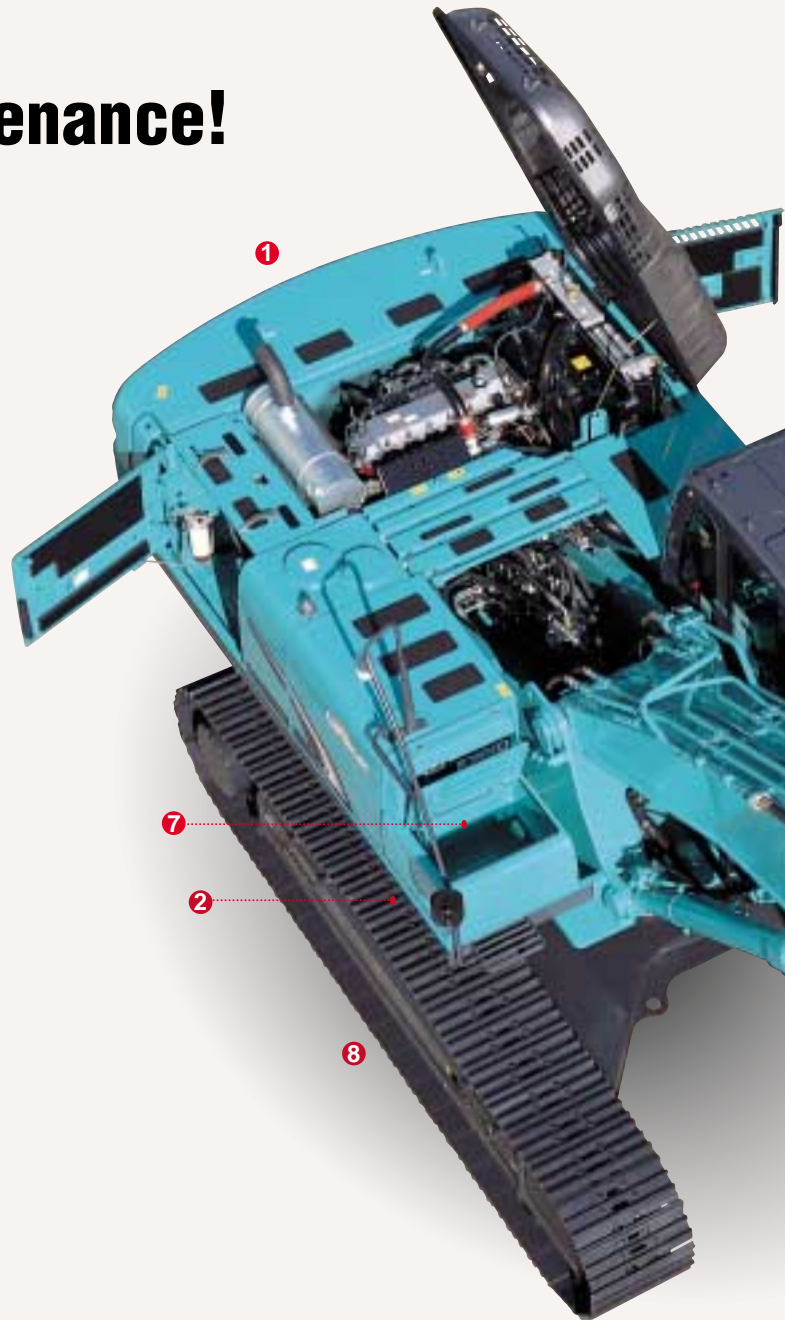

### Quick Oil Drain Valves for Quick Maintenance



Quick drain valve

1 A quick drain valve, which requires no tools, is provided as standard equipment.



Fuel drain valve

2 To facilitate fuel tank cleaning, the fuel drain valve was made larger and fitted with a flange on the bottom.

### More Efficient Maintenance Inside the Cab



Drain type  
Detachable

3 Detachable two-piece floor mat with handles for easy removal. A floor drain is located under the mat.



4 Easy-access fuse box. More finely differentiated fuses make it easier to locate malfunctions.

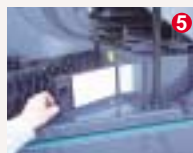

5 Air conditioner filter can be easily removed without tools for cleaning.



6 Hour meter can be checked while standing on the ground.



7 Large-capacity tool box can hold up to three pallets.

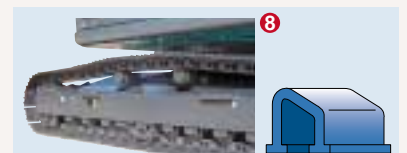

8 Special crawler frame design is easily cleaned of mud.



Access through the left side cover

### Parallel Cooling Units Are Easy to Clean

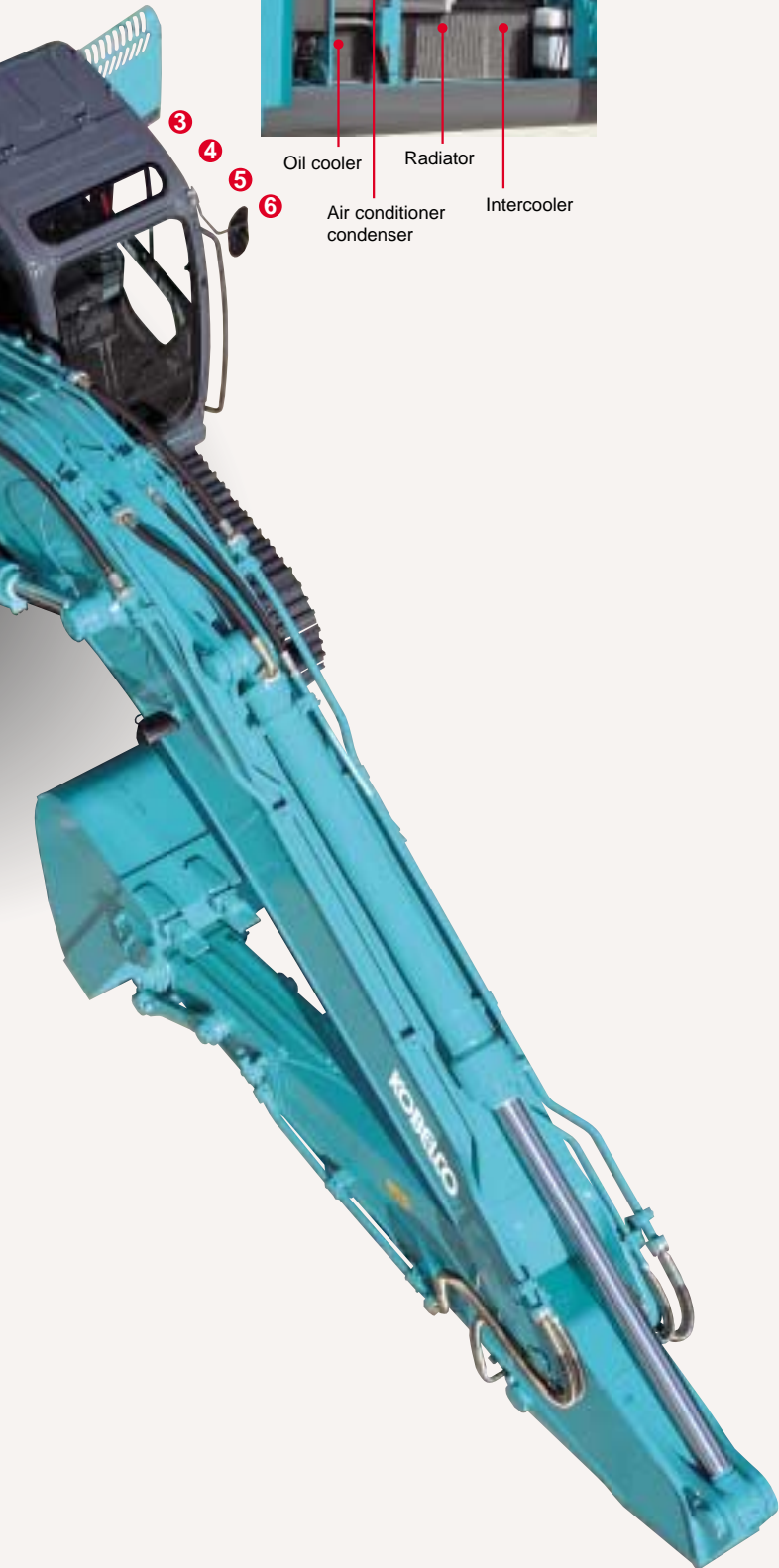
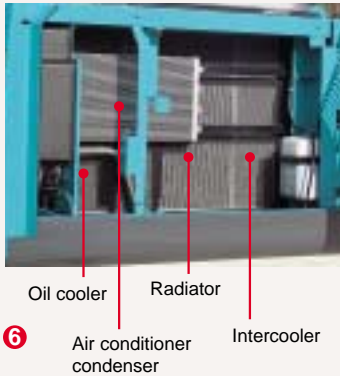

### Long-Life Hydraulic Oil Reduces Replacement Costs



The long-life hydraulic oil features a base oil with excellent demulsification, with optimized wear-resistant additives and antioxidants that help to boost the service life to 5,000 hours and greatly reduce the number of changes necessary.

### Highly Durable Super-fine Filter



● Super-fine filter

The high-capacity hydraulic oil filter incorporates glass fiber with superior cleaning power and durability. With a replacement cycle of 1,000 hours and a construction that allows replacement of the filter element only, it's both highly effective and highly economical.

### Double-Element Air Cleaner as Standard



The large-capacity element features a double-filter structure that keeps the engine running clean even in dusty environments.

Air cleaner (double element)

### New-Design Fuel Filter Catches 95% of Dust and Impurities



The large-capacity fuel filter is designed specifically for common rail engines. With an increased filtering performance to 2-micron precision, this high-grade filter catches 95% of all dust particles and other impurities in the fuel.

### Monitor Display with Essential Information for Accurate Maintenance Checks



- Displays only the maintenance information that's needed, when it's needed.
- Self-diagnostic function that provides early-warning detection and display of electrical system malfunctions.
- Record previous breakdowns, including irregular and transient malfunctions.

### Choice of 16 Languages for Monitor Display

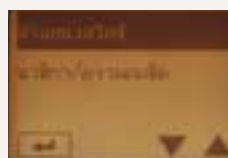

With messages including those requiring urgent action displayed in the local language, users in all parts of the world can work with greater peace of mind.

充電不良 Chinese	Lichtmaschine defekt German	CHARGE ERROR English	CHARGE ERROR English (US)
ERREUR DE CHARGE French	PENGISIAN BATT. RUSAK Indonesian	ISO	ERRORE DI CARICA Italian
チャージ Japanese	KESALAHAN CAS Malay	မြားရမ်းဝင်ပုံ Myanmar(Burmese)	ERRO DE CARGA Portuguese
ERROR EN CARGA Spanish	தவறாக திணிததல் Tamil	பிழை Thai	Sạc Điện Bị Lỗi Vietnamese

*The GEOSPEC Difference:*

# Designed from the Operator's Point of View



## Wide Field of View Liberates the Operator

The front field of view easily clears ISO standards, while the peripheral view reduces blind spots to a minimum.



- A long wiper covers a wide area for a broad view in bad weather.
- Back mirrors provide a safe view of the rear.
- Reinforced green glass windows meet European standards.

## Wide-Access Cab Ensures Smooth Entry and Exit

The left control box lifts up with the safety lock lever to add 10° to the cab entry angle for easy entrance and exit.



## Plenty of Foot Room

With a total width of 1,005 mm, the cab has 35 mm more front-to-back foot room than previous models. The travel pedal is larger for greater operator comfort.

## Reduced Vibration for Fatigue-Free Operation

The rigid cab construction and liquid-filled viscous cab mounts minimize cab vibration. In addition, the use of new lower rollers on the crawlers cuts travel vibration in half compared with previous models.

## In-Cab Noise is Reduced by 4dB Compared with Previous Models.

## Creating a Comfortable Operating Environment



- Seat can be reclined to horizontal position





**The GEOSPEC Difference:  
Imagining Possible Scenarios  
and Preparing in Advance**

**Bracket for Attaching a Head Guard Provided as Standard Equipment**



A bracket is provided as standard equipment that allows the optional head guard to be simply bolted on.

**Safety Features That Take Various Scenarios into Consideration**



● Firewall separates the pump compartment from the engine



● Hammer for emergency exit



● Swing flashers/rear working lights



● Level indicator that shows degree of machine tilt

- Thermal guard prevents contact with hot components during engine inspections
- Hand rails meet European standards
- Retractable seatbelt requires no manual adjustment

**Optional Features That Further Enhance Safety**

- Cab working light
- Fire extinguisher
- Rearview camera and monitor
- One-way call
- Yellow rotary light
- Travel alarm

**Newly Designed Information Display Prioritizes Visual Recognition**

The analog gauge provides information that's easy to read regardless of the operating environment. The information display screen has been enlarged, and a visor is attached to further enhance visibility.



● Double slide and suspension seat



● Powerful automatic air conditioner



● Spacious luggage tray



● One-touch lock release simplifies opening and closing the front window



● Large cup holder

- Two-speaker FM radio with station select
- New interior design and materials create an elegant feel



# Specifications

## Engine

Model	HINO J08E
Type:	Direct injection, water-cooled, 4-cycle diesel engine with turbocharger, intercooler (Comply with EU (NRMM) Stage IIIA, US EPA Tier III, and Japanese latest Exhaust Emission Regulations)
No. of cylinders:	6
Bore and stroke:	112 mm X 130 mm
Displacement:	7.684 L
Rated power output:	209 kW/2,100 min <sup>-1</sup> (ISO14396:2002) 197 kW/2,100 min <sup>-1</sup> (ISO9249:2007)*
Max. torque:	998 N·m/1,600 min <sup>-1</sup> (ISO14396:2002) 969 N·m/1,600 min <sup>-1</sup> (ISO9249:2007)*

\*Previous indication

## Hydraulic System

Pump	
Type:	Two variable displacement pumps + 1 gear pump
Max. discharge flow:	2 X 294 L/min, 1 X 20 L/min
Relief valve setting	
Boom, arm and bucket:	34.3 MPa {350 kgf/cm <sup>2</sup> }
Power Boost:	37.8 MPa {385 kgf/cm <sup>2</sup> }
Travel circuit:	34.3 MPa {350 kgf/cm <sup>2</sup> }
Swing circuit:	29.0 MPa {296 kgf/cm <sup>2</sup> }
Control circuit:	5.0 MPa {50 kgf/cm <sup>2</sup> }
Pilot control pump:	Gear type
Main control valves:	8-spool
Oil cooler:	Air cooled type

## Swing System

Swing motor:	Axial-piston motor
Brake:	Hydraulic; locking automatically when the swing control lever is in the neutral position
Parking brake:	Hydraulic disc brake
Swing speed:	10.0 min <sup>-1</sup> {rpm}
Tail swing radius:	3,500 mm
Min. front swing radius:	4,370 mm

## Attachments

Backhoe bucket and arm combination

Use			Backhoe bucket					
			Normal digging				Light-duty	Heavy digging
Bucket capacity	(ISO heaped)	m <sup>3</sup>	1.2	1.4	1.6	2.3	1.8	1.4
	(CECE heaped)	m <sup>3</sup>	0.84	1.0	1.2	1.84	1.4	1.0
Opening width	With side cutter	mm	1,240	1,420	1,570	1,930	—	1,390
	Without side cutter	mm	1,110	1,300	1,450	1,760	1,680	1,330
No. of bucket teeth			4	5	5	6	5	5
Bucket weight		kg	930	1,070	1,100	1,500	1,200	1,300
Combinations	2.25 m super short arm		○	○	○	○	○	○
	2.6 m short arm		○	○	○	×	△	○
	3.3 m standard arm		○	○	○	×	×	○
	4.15 m long arm		○	△	×	×	×	×

○ Recommended △ Loading only × Not recommended

## Travel System

Travel motors:	2 X axial-piston, two-step motors
Travel brakes:	Hydraulic brake per motor
Parking brakes	Oil disc brake per motor
Travel shoes:	45 each side (SK330)
	48 each side (SK350LC)
Travel speed:	5.6/3.3 km/h
Drawbar pulling force:	322 kN {32.8 tf} (J 1309)
Gradeability:	70 % {35°}
Ground clearance:	500 mm

## Cab & Control

### Cab

All-weather, sound-suppressed steel cab mounted on the silicon-sealed viscous mounts and equipped with a heavy, insulated floor mat.

### Control

Two hand levers and two foot pedals for travel

Two hand levers for excavating and swing

Electric rotary-type engine throttle

## Boom, Arm & Bucket

Boom cylinders:	140 mm X 1,550 mm
Arm cylinder:	170 mm X 1,788 mm
Bucket cylinder:	150 mm X 1,193 mm

## Refilling Capacities & Lubrications

Fuel tank:	580 L
Cooling system:	31.1 L
Engine oil:	28.5 L
Travel reduction gear:	2 X 9.5 L
Swing reduction gear:	7.4 L
Hydraulic oil tank:	280 L tank oil level 353 L hydraulic system





## Working Ranges

Unit: m

Range	Arm	6.50 m Boom			
		Super Short 2.25 m	Short 2.6 m	Standard 3.3 m	Long 4.15 m
a - Max. digging reach		10.35	10.61	11.26	11.97
b - Max. digging reach at ground level		10.14	10.4	11.06	11.79
c - Max. digging depth		6.51	6.86	7.56	8.41
d - Max. digging height		10.28	10.26	10.58	10.7
e - Max. dumping clearance		7.05	7.06	7.37	7.53
f - Min. dumping clearance		3.73	3.32	2.62	1.77
g - Max. vertical wall digging depth		5.28	5.84	6.61	7.15
h - Min. swing radius		4.48	4.45	4.37	4.43
i - Horizontal digging stroke at ground level		3.4	4.21	5.82	7.21
j - Digging depth for 2.4 m (8') flat bottom		6.31	6.67	7.4	8.27
Bucket capacity ISO heaped m <sup>3</sup>		2.3	1.6	1.4	1.2

### Digging Force (ISO 6015)

Unit: kN (tf)

Arm length	Super Short 2.25 m	Short 2.6 m	Standard 3.3 m	Long 4.15 m
Bucket digging force	220 (22.4) 241 (24.6)	221 (22.5) 244 (24.9)*	222 (22.6) 244 (24.9)*	221 (22.5) 243 (24.8)*
Arm crowding force	231 (23.6) 255 (26.0)	205 (20.9) 225 (22.9)*	165 (16.8) 181 (18.5)*	140 (14.3) 154 (15.7)*

\*Power Boost engaged.

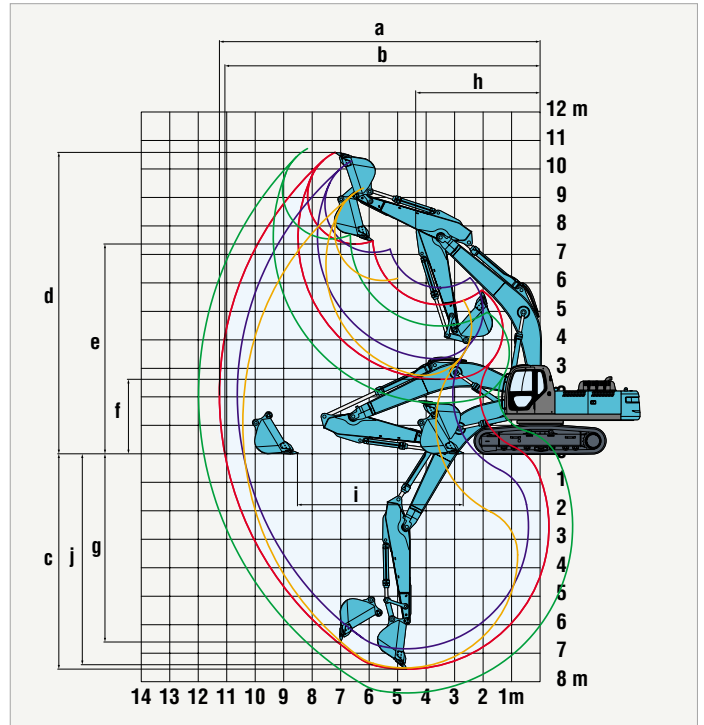

- Super Short Arm
- Short Arm
- Standard Arm
- Long Arm



## Dimensions

Arm length	Super Short 2.25 m	Short 2.6 m	Standard 3.3 m	Long 4.15 m
<b>A</b> Overall length	11,410	11,280	11,200	11,230
<b>B</b> Overall height (to top of boom)	3,760	3,640	3,420	3,590
<b>C</b> Overall width	SK330	3,200	3,200	3,200
	SK350LC	3,200	3,200	3,200
<b>D</b> Overall height (to top of cab)	3,160	3,160	3,160	3,160
<b>E</b> Ground clearance of rear end*	1,190	1,190	1,190	1,190
<b>F</b> Ground clearance*	500	500	500	500

	Unit: mm			
<b>G</b> Tail swing radius	3,500	3,500	3,500	3,500
<b>G'</b> Distance from center of swing to rear end	3,500	3,500	3,500	3,500
<b>H</b> Tumbler distance	SK330	3,730	3,730	3,730
	SK350LC	4,050	4,050	4,050
<b>I</b> Overall length of crawler	SK330	4,650	4,650	4,650
	SK350LC	4,980	4,980	4,980
<b>J</b> Track gauge	SK330	2,600	2,600	2,600
	SK350LC	2,600	2,600	2,600
<b>K</b> Shoe width	600/800			
<b>L</b> Overall width of upperstructure	2,950	2,950	2,950	2,950

\* Without including height of shoe lug.

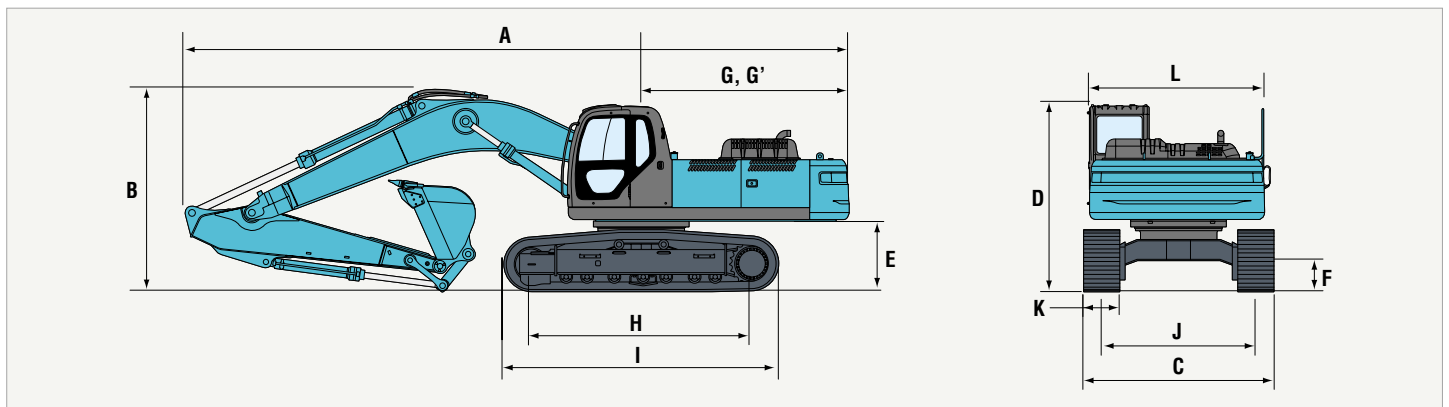

## Operating Weight & Ground Pressure

In standard trim, with standard boom, 3.3 m arm, and 1.4 m<sup>3</sup> ISO heaped bucket

Shaped	mm	Triple grouser shoes (even height)	
		600	800
Overall width	mm	SK330 3,200	SK350LC 3,400
Ground pressure	kPa (kgf/cm <sup>2</sup> )	SK330	68 (0.70)
		SK350LC	53 (0.54)
Operating weight	kg	SK330	33,600
		SK350LC	34,300

# Lifting Capacities

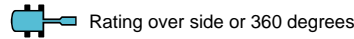
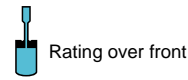
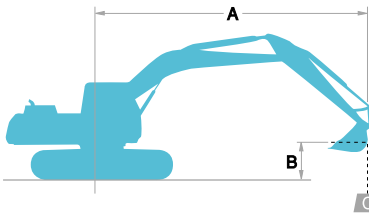

- A - Reach from swing centerline to bucket hook
- B - Bucket hook height above/below ground
- C - Lifting capacities in kilograms
- Max. discharge pressure: 37.8 MPa (385 kgf/cm<sup>2</sup>)















SK330		Standard Arm: 3.3 m Bucket: 1.4 m <sup>3</sup> ISO heaped 1,070 kg Shoe: 600 mm														
B \ A		1.5 m		3.0 m		4.5 m		6.0 m		7.5 m		9.0 m		At Max. Reach		Radius
7.5 m	kg									*5,640	*5,640			*3,650	*3,650	8.05 m
6.0 m	kg									*5,840	*5,840			*3,600	*3,600	8.88 m
4.5 m	kg							*7,320	*7,320	*6,370	*6,370	*5,840	4,570	*3,690	*3,690	9.41 m
3.0 m	kg			*12,590	*12,590	*11,730	*11,730	*8,630	*8,630	*7,070	6,030	*6,180	4,390	*3,920	3,830	9.67 m
1.5 m	kg			*7,080	*7,080	*13,950	12,320	*9,850	8,010	*7,760	5,680	6,110	4,200	*4,320	3,680	9.70 m
G. L.	kg			*10,390	*10,390	*15,020	11,670	*10,670	7,570	7,930	5,410	5,960	4,050	*4,980	*3,720	9.49 m
-1.5 m	kg	*10,760	*10,760	*14,890	*14,890	*15,030	11,460	*10,920	7,360	7,770	5,260	5,890	3,990	5,870	3,980	9.02 m
-3.0 m	kg	*15,190	*15,190	*20,250	*20,250	*14,170	11,530	*10,500	7,340	7,770	5,260			6,740	4,580	8.26 m
-4.5 m	kg	*20,200	*20,200	*16,970	*16,970	*12,270	11,820	*9,150	7,530					*7,250	5,890	7.10 m
-6.0 m	kg					*8,560	*8,560							*7,090	*7,090	5.29 m















SK330		Standard Arm: 3.3 m Bucket: 1.4 m <sup>3</sup> ISO heaped 1,070 kg Shoe: 800 mm														
B \ A		1.5 m		3.0 m		4.5 m		6.0 m		7.5 m		9.0 m		At Max. Reach		Radius
7.5 m	kg									*5,640	*5,640			*3,650	*3,650	8.05 m
6.0 m	kg									*5,840	*5,840			*3,600	*3,600	8.88 m
4.5 m	kg							*7,320	*7,320	*6,370	*6,370	*5,840	4,730	*3,690	*3,690	9.41 m
3.0 m	kg			*12,590	*12,590	*11,730	*11,730	*8,630	*8,630	*7,070	6,230	*6,180	4,550	*3,920	*3,920	9.67 m
1.5 m	kg			*7,080	*7,080	*13,950	12,710	*9,850	8,280	*7,760	5,880	6,340	4,360	*4,320	3,820	9.70 m
G. L.	kg			*10,390	*10,390	*15,020	12,060	*10,670	7,840	8,220	5,610	6,180	4,210	*4,980	*3,870	9.49 m
-1.5 m	kg	*10,760	*10,760	*14,890	*14,890	*15,030	11,850	*10,920	7,620	8,060	5,460	6,120	4,150	*6,070	4,140	9.02 m
-3.0 m	kg	*15,190	*15,190	*20,250	*20,250	*14,170	11,920	*10,500	7,610	*8,040	5,460			*6,990	4,750	8.26 m
-4.5 m	kg	*20,200	*20,200	*16,970	*16,970	*12,270	12,220	*9,150	7,790					*7,250	6,100	7.10 m
-6.0 m	kg					*8,560	*8,560							*7,090	*7,090	5.29 m















SK330		Long Arm: 4.15 m Bucket: 1.2 m <sup>3</sup> ISO heaped 930 kg Shoe: 600 mm														
B \ A		1.5 m		3.0 m		4.5 m		6.0 m		7.5 m		9.0 m		At Max. Reach		Radius
7.5 m	kg													*2,830	*2,830	8.85 m
6.0 m	kg													*2,780	*2,780	9.62 m
4.5 m	kg									*5,630	*5,630	*5,220	4,670	*2,850	*2,850	10.11 m
3.0 m	kg			*15,930	*15,930	*10,040	*10,040	*7,650	*7,650	*6,390	6,150	*5,640	4,440	*3,020	*3,020	10.35 m
1.5 m	kg			*12,530	*12,530	*12,620	*12,620	*9,030	8,170	*7,180	5,740	*6,090	4,210	*3,310	3,230	10.38 m
G. L.	kg	*6,110	*6,110	*11,720	*11,720	*14,280	11,750	*10,090	7,600	*7,830	5,390	5,910	4,000	*3,780	3,230	10.18 m
-1.5 m	kg	*9,500	*9,500	*14,260	*14,260	*14,880	11,310	*10,650	7,260	7,680	5,170	5,780	3,870	*4,520	3,410	9.74 m
-3.0 m	kg	*12,990	*12,990	*18,060	*18,060	*14,560	11,210	*10,620	7,140	7,590	5,080	5,760	3,860	5,710	3,830	9.04 m
-4.5 m	kg	*16,880	*16,880	*19,250	*19,250	*13,300	11,380	*9,830	7,210	*7,430	5,160			*6,700	4,700	8.00 m
-6.0 m	kg			*15,020	*15,020	*10,720	*10,720	*7,800	7,530					*7,000	6,760	6.46 m















SK330		Long Arm: 4.15 m Bucket: 1.2 m <sup>3</sup> ISO heaped 930 kg Shoe: 800 mm														
B \ A		1.5 m		3.0 m		4.5 m		6.0 m		7.5 m		9.0 m		At Max. Reach		Radius
7.5 m	kg													*2,830	*2,830	8.85 m
6.0 m	kg													*2,780	*2,780	9.62 m
4.5 m	kg									*5,630	*5,630	*5,220	4,830	*2,850	*2,850	10.11 m
3.0 m	kg			*15,930	*15,930	*10,040	*10,040	*7,650	*7,650	*6,390	6,350	*5,640	4,600	*3,020	*3,020	10.35 m
1.5 m	kg			*12,530	*12,530	*12,620	*12,620	*9,030	8,440	*7,180	5,930	*6,090	4,370	*3,310	*3,310	10.38 m
G. L.	kg	*6,110	*6,110	*11,720	*11,720	*14,280	12,140	*10,090	7,870	*7,830	5,590	6,140	4,160	*3,780	3,370	10.18 m
-1.5 m	kg	*9,500	*9,500	*14,260	*14,260	*14,880	11,700	*10,650	7,520	7,970	5,370	6,000	4,030	*4,520	3,550	9.74 m
-3.0 m	kg	*12,990	*12,990	*18,060	*18,060	*14,560	11,610	*10,620	7,400	7,870	5,280	5,980	4,020	*5,830	3,980	9.04 m
-4.5 m	kg	*16,880	*16,880	*19,250	*19,250	*13,300	11,780	*9,830	7,480	*7,430	5,360			*6,700	4,880	8.00 m
-6.0 m	kg			*15,020	*15,020	*10,720	*10,720	*7,800	7,800					*7,000	*7,000	6.46 m



SK350 <sup>LC</sup>		Standard Arm: 3.3 m Bucket: 1.4 m <sup>3</sup> ISO heaped 1,070 kg Shoe: 600 mm														
B \ A		1.5 m		3.0 m		4.5 m		6.0 m		7.5 m		9.0 m		At Max. Reach		Radius
																
7.5 m	kg									*5,640	*5,640			*3,650	*3,650	8.05 m
6.0 m	kg									*5,840	*5,840			*3,600	*3,600	8.88 m
4.5 m	kg							*7,320	*7,320	*6,370	*6,370	*5,840	4,680	*3,690	*3,690	9.41 m
3.0 m	kg			*12,590	*12,590	*11,730	*11,730	*8,630	*8,630	*7,070	6,160	*6,180	4,490	*3,920	*3,920	9.67 m
1.5 m	kg			*7,080	*7,080	*13,950	12,580	*9,850	8,190	*7,760	5,810	*6,530	4,310	*4,320	3,770	9.70 m
G. L.	kg	*10,760	*10,760	*10,390	*10,390	*15,020	11,930	*10,670	7,750	*8,270	5,540	*6,770	4,160	*4,980	3,820	9.49 m
-1.5 m	kg	*15,190	*15,190	*14,890	*14,890	*15,030	11,720	*10,920	7,530	*8,430	5,390	*6,370	4,100	*6,070	4,080	9.02 m
-3.0 m	kg	*20,200	*20,200	*20,250	*20,250	*14,170	11,790	*10,500	7,520	*8,040	5,390			*6,990	4,690	8.26 m
-4.5 m	kg			*16,970	*16,970			*12,270	12,080	*9,150	7,700			*7,250	6,030	7.10 m
-6.0 m	kg					*8,560	*8,560							*7,090	*7,090	5.29 m

SK350 <sup>LC</sup>		Standard Arm: 3.3 m Bucket: 1.4 m <sup>3</sup> ISO heaped 1,070kg Shoe: 800 mm														
B \ A		1.5 m		3.0 m		4.5 m		6.0 m		7.5 m		9.0 m		At Max. Reach		Radius
																
7.5 m	kg									*5,640	*5,640			*3,650	*3,650	8.05 m
6.0 m	kg									*5,840	*5,840			*3,600	*3,600	8.88 m
4.5 m	kg							*7,320	*7,320	*6,370	*6,370	*5,840	4,840	*3,690	*3,690	9.41 m
3.0 m	kg			*12,590	*12,590	*11,730	*11,730	*8,630	*8,630	*7,070	6,360	*6,180	4,660	*3,920	*3,920	9.67 m
1.5 m	kg			*7,080	*7,080	*13,950	12,980	*9,850	8,460	*7,760	6,010	*6,530	4,470	*4,320	3,920	9.70 m
G. L.	kg			*10,390	*10,390	*15,020	12,330	*10,670	8,020	*8,270	5,740	*6,770	4,320	*4,980	3,970	9.49 m
-1.5 m	kg	*10,760	*10,760	*14,890	*14,890	*15,030	12,120	*10,920	7,800	*8,430	5,600	*6,370	4,260	*6,070	4,240	9.02 m
-3.0 m	kg	*15,190	*15,190	*20,250	*20,250	*14,170	12,190	*10,500	7,790	*8,040	5,590			*6,990	4,870	8.26 m
-4.5 m	kg	*20,200	*20,200	*16,970	*16,970			*12,270	*12,270	*9,150	7,970			*7,250	6,250	7.10 m
-6.0 m	kg					*8,560	*8,560							*7,090	*7,090	5.29 m

SK350 <sup>LC</sup>		Long Arm: 4.15 m Bucket: 1.2 m <sup>3</sup> ISO heaped 930 kg Shoe: 600 mm														
B \ A		1.5 m		3.0 m		4.5 m		6.0 m		7.5 m		9.0 m		At Max. Reach		Radius
																
7.5 m	kg													*2,830	*2,830	8.85 m
6.0 m	kg											*4,670	*4,670	*2,780	*2,780	9.62 m
4.5 m	kg									*5,630	*5,630	*5,220	4,780	*2,850	*2,850	10.11 m
3.0 m	kg			*15,930	*15,930	*10,040	*10,040	*7,650	*7,650	*6,390	6,280	*5,640	4,550	*3,020	*3,020	10.35 m
1.5 m	kg			*12,530	*12,530	*12,620	*12,620	*9,030	8,350	*7,180	5,870	*6,090	4,310	*3,310	*3,310	10.38 m
G. L.	kg	*6,110	*6,110	*11,720	*11,720	*14,280	12,010	*10,090	7,780	*7,830	5,520	*6,460	4,110	*3,780	3,320	10.18 m
-1.5 m	kg	*9,500	*9,500	*14,260	*14,260	*14,880	11,560	*10,650	7,440	*8,210	5,300	*6,630	3,980	*4,520	3,500	9.74 m
-3.0 m	kg	*12,990	*12,990	*18,060	*18,060	*14,560	11,470	*10,620	7,310	*8,160	5,210	*6,310	3,960	*5,830	3,930	9.04 m
-4.5 m	kg	*16,880	*16,880	*19,250	*19,250	*13,300	11,640	*9,830	7,390	*7,430	5,290			*6,700	4,820	8.00 m
-6.0 m	kg			*15,020	*15,020	*10,720	*10,720	*7,800	7,710					*7,000	6,920	6.46 m

SK350 <sup>LC</sup>		Long Arm: 4.15 m Bucket: 1.2 m <sup>3</sup> ISO heaped 930 kg Shoe: 800 mm														
B \ A		1.5 m		3.0 m		4.5 m		6.0 m		7.5 m		9.0 m		At Max. Reach		Radius
																
7.5 m	kg													*2,830	*2,830	8.85 m
6.0 m	kg											*4,670	*4,670	*2,780	*2,780	9.62 m
4.5 m	kg									*5,630	*5,630	*5,220	4,940	*2,850	*2,850	10.11 m
3.0 m	kg			*15,930	*15,930	*10,040	*10,040	*7,650	*7,650	*6,390	*6,390	*5,640	4,710	*3,020	*3,020	10.35 m
1.5 m	kg			*12,530	*12,530	*12,620	*12,620	*9,030	8,620	*7,180	6,070	*6,090	4,480	*3,310	*3,310	10.38 m
G. L.	kg	*6,110	*6,110	*11,720	*11,720	*14,280	12,410	*10,090	8,050	*7,830	5,730	*6,460	4,270	*3,780	3,460	10.18 m
-1.5 m	kg	*9,500	*9,500	*14,260	*14,260	*14,880	11,960	*10,650	7,700	*8,210	5,500	*6,630	4,140	*4,520	3,650	9.74 m
-3.0 m	kg	*12,990	*12,990	*18,060	*18,060	*14,560	11,870	*10,620	7,580	*8,160	5,410	*6,310	4,120	*5,830	4,090	9.04 m
-4.5 m	kg	*16,880	*16,880	*19,250	*19,250	*13,300	12,040	*9,830	7,660	*7,430	5,490			*6,700	5,010	8.00 m
-6.0 m	kg			*15,020	*15,020	*10,720	*10,720	*7,800	*7,800					*7,000	*7,000	6.46 m

- Notes:**
- Do not attempt to lift or hold any load that is greater than these lift capacities at their specified lift point radius and heights. Weight of all accessories must be deducted from the above lift capacities.
  - Lift capacities are based on machine standing on level, firm, and uniform ground. User must make allowance for job conditions such as soft or uneven ground, out of level conditions, side loads, sudden stopping of loads, hazardous conditions, experience of personnel, etc.
  - Bucket lift hook defined as lift point.
  - The above lifting capacities are in compliance with ISO 10567. They do not exceed 87% of hydraulic lifting capacity or 75% of tipping load. Lifting capacities marked with an asterisk (\*) are limited by hydraulic capacity rather than tipping load.
  - Operator should be fully acquainted with the Operator's and Maintenance Instructions before operating this machine. Rules for safe operation of equipment should be adhered to at all times.
  - Lift capacities apply to only machine as originally manufactured and normally equipped by KOBELCO CONSTRUCTION MACHINERY CO., LTD.

## STANDARD EQUIPMENT

### ENGINE

- Engine, HINO J08E, Diesel engine with turbocharger and intercooler
- Automatic engine deceleration
- Auto Idle Stop (AIS)
- Batteries (2 x 12V - 96Ah)
- Starting motor (24V - 5 kW), 50 amp alternator
- Removable clean-out screen for radiator
- Automatic engine shut-down for low engine oil pressure
- Engine oil pan drain valve
- Double element air cleaner

### CONTROL

- Working mode selector (H-mode and S-mode)
- Power Boost

### SWING SYSTEM & TRAVEL SYSTEM

- Swing rebound prevention system
- Straight propel system
- Two-speed travel with automatic shift down
- Sealed & lubricated track links
- Grease-type track adjusters
- Automatic swing brake

### HYDRAULIC

- Arm regeneration system
- Auto warm up system
- Aluminum hydraulic oil cooler

### MIRRORS & LIGHTS

- Two rearview mirrors
- Three front and two rear working lights
- Swing flashers

### CAB & CONTROL

- Two control levers, pilot-operated
- Tow eyes
- Horn, electric
- Integrated left-right slide-type control box
- Cab, all-weather sound suppressed type
- Ashtray
- Cigarette lighter
- Cab light (interior)
- Coat hook
- Luggage tray
- Large cup holder
- Detachable two-piece floor mat
- 7-way adjustable suspension seat
- Retractable seatbelt
- Headrest
- Handrails
- Heater and defroster
- Intermittent windshield wiper with double-spray washer
- Skylight
- Tinted safety glass
- Pull-type front window and removable lower front window
- Easy-to-read multi-display monitor
- Automatic air conditioner
- Emergency escape hammer
- Radio, AM/FM Stereo with speakers
- Travel alarm (optional for NZ)
- Level indicator (optional for NZ)

## OPTIONAL EQUIPMENT

- Wide range of buckets
- Various optional arms
- Wide range of shoes
- Boom safety valve
- Arm safety valve
- Front-guard protective structures
- Additional hydraulic circuit

Note: Standard and optional equipment may vary. Consult your KOBELCO dealer for specifics.

Note: This catalog may contain attachments and optional equipment that are not available in your area. And it may contain photographs of machines with specifications that differ from those of machines sold in your areas. Please consult your nearest KOBELCO distributor for those items you require. Due to our policy of continuous product improvements all designs and specifications are subject to change without advance notice. Copyright by **KOBELCO CONSTRUCTION MACHINERY CO., LTD.** No part of this catalog may be reproduced in any manner without notice.

### KOBELCO CONSTRUCTION MACHINERY CO., LTD.

17-1, Higashigotanda 2-chome, Shinagawa-ku, Tokyo 141-8626 JAPAN  
Tel: +81 (0) 3-5789-2146 Fax: +81 (0) 3-5789-2135  
[www.kobelco-kenki.co.jp/english\\_index.html](http://www.kobelco-kenki.co.jp/english_index.html)

Inquiries To: