

**STANDARD EQUIPMENT**

**ENGINE**

- Engine, HINO P11C, diesel engine with turbocharger and intercooler
- Automatic engine deceleration
- Auto Idle Stop (AIS)
- Batteries (2 x 12V - 112Ah)
- Starting motor (24V - 6kW), 60 amp alternator
- Automatic engine shut-down for low engine oil pressure
- Engine oil pan drain cock
- Double element air cleaner

**CONTROL**

- Working mode selector (H-mode, S-mode and ECO-mode)
- Power Boost

**SWING SYSTEM & TRAVEL SYSTEM**

- Swing rebound prevention system
- Two-speed travel with automatic shift down
- Sealed & lubricated track links
- Grease-type track adjusters
- 800mm HD triple grouser shoe
- Automatic swing brake
- Tow eyes

**HYDRAULIC**

- Boom regeneration system
- Auto warm up system
- Aluminum hydraulic oil cooler
- Arm interflow system
- Hydraulic fluid filter clog detector

**MIRRORS & LIGHTS**

- Two rear view mirrors
- Five front working lights (Two for boom, one for boom cylinder, one for right storage box and one for cab)

**CAB & CONTROL**

- Two control levers, pilot-operated
- Horn, electric
- Cab light (interior)
- Luggage tray
- Large cup holder
- Detachable two-piece floor mat
- Headrest
- Handrails
- Intermittent windshield wiper with double-spray washer
- Tinted safety glass
- Pull-up type front window and removable lower front window
- Easy-to-read multi-display color monitor
- Automatic air conditioner
- Emergency escape hammer
- KOMEXS
- Suspension seat
- 24V outlet
- Multi control valve

**OPTIONAL EQUIPMENT**

- N&B Piping
- Refilling pump
- Rear view camera
- 600mm HD triple grouser shoe
- ROPS cab
- Two cab lights
- Travel alarm
- Additional track guide
- Step for 800mm shoes

Note: Standard and optional equipment may vary. Consult your KOBELCO dealer for specifics.

Note: This catalog may contain attachments and optional equipment that are not available in your area. And it may contain photographs of machines with specifications that differ from those of machines sold in your areas. Please consult your nearest KOBELCO distributor for those items you require. Due to our policy of continuous product improvements all designs and specifications are subject to change without advance notice. Copyright by **KOBELCO CONSTRUCTION MACHINERY CO., LTD.** No part of this catalog may be reproduced in any manner without notice.

**KOBELCO CONSTRUCTION MACHINERY CO., LTD.**

5-15, Kitashinagawa 5-chome, Shinagawa-ku, Tokyo 141-8626 JAPAN  
Tel: +81 (0) 3-5789-2146 Fax: +81 (0) 3-5789-2135  
<https://www.kobelcocm-global.com/>

Inquiries To:





# Power Meets Efficiency

Increase in  
productivity  
means  
"Power"

14%\*  
Higher fuel  
saving means  
"Efficiency"

In line with KOBELCO's concept of earth-friendly construction machinery that will work long and hard on any site on the planet, the rugged machine body is newly designed, and comprehensive reinforcement makes the attachment more robust. It all adds up to KOBELCO's toughest ever mining excavator. The latest hydraulics technology delivers both high-powered output and lower fuel consumption. As the 10th generation model of KOBELCO's SK series, the SK500XDLC SK520XDLC meets the needs of the most punishing mining sites with a performance that simply astounds.



\*Compared to H-mode on the SK480LC-8



# Even stronger attachment

Increase in productivity means "Power"

The boom and arm that take the greatest punishment are significantly reinforced.

## Newly developed boom made of thicker steel plate

The XD boom features reinforcement plates, which increases longevity even under the toughest working conditions.

### XD boom **NEW**

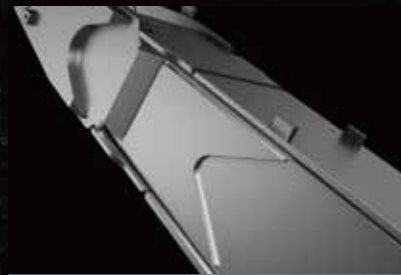

Boom top



Bottom side of Boom



Top side of Boom

### ME boom **NEW**

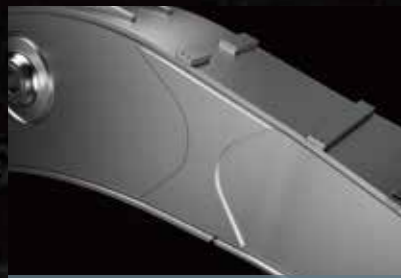

Boom side



Bottom side of Boom



Boom foot / Boom foot boss



### Rock Guards

Specially designed long, solid rock guard installed to prevent damage to arm.



### Reinforced 2.1m<sup>3</sup> bucket for heavy duty

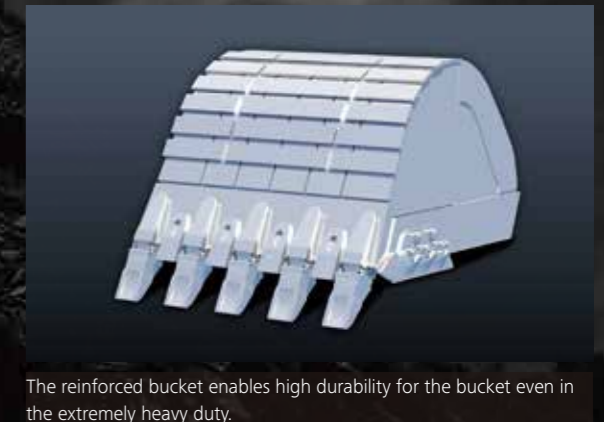

The reinforced bucket enables high durability for the bucket even in the extremely heavy duty.

### Reinforced arm exhibits strength

Thickness of steel plate for arm top and arm foot has been increased to deliver more strength for toughest working conditions.

### XD arm **NEW**



Arm top



Arm foot

### ME arm **NEW**



Arm top



Arm foot

### Upper Under Covers

Thick covers with increased durability compared to standard models.





# Increase in productivity means "Power"

Powerful travel system for easy transit over loose stones, and highly reliable filtration system ensure higher machine performance.



## Crawlers Built for Unbeatable Durability

### Reinforced Guide Frame



Reinforced guide frame prevents deformation caused by impact or encroaching of loose stones.

### Track Guides



Large, reinforced track guides are installed in two locations.

### Thicker steel plate for shoes



Reinforced HD shoes of thick steel plate to master rough, stony ground.

### Track Links



The durability of the track link is increased compared to standard models.

### Lower Under Cover



Hydraulic piping and equipment protected against damage from rubble and stony ground.

## Built to operate in tough working environment

### Hydraulic Drive for Engine Cooling Fan; Independent Oil Cooler Fan NEW



Hydraulic drive optimizes the cooling fan rotation speed to improve fuel economy and reduce noise. Also, the independent oil cooler fan better matches cooling to the hydraulic oil temperature, for optimal oil temperature control.

## Improved Filtration System Reliability

Clean, contaminant-free fuel and hydraulic fluid are essential to stable performance. The improved filtration systems reduce the risk of mechanical trouble and enhance longevity and durability.

### Fuel Filter NEW

The pre-filter, with built-in water separator maximizes filtering performance.

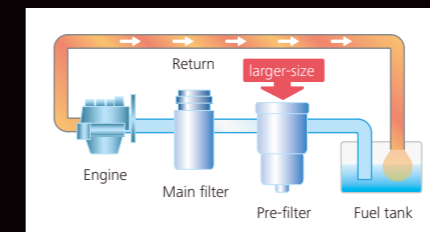

### Hydraulic Fluid Filter NEW

Recognized as the best in the industry, our Premium-fine filter separates out even the smallest particles. New cover prevents contamination when changing filters.



### Metal Mesh Cover Air Cleaner NEW

Metal mesh cover ensures strength and durability.

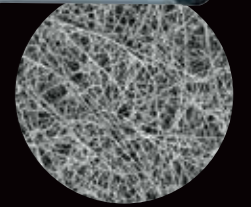

Enlarged filter image

### Hydraulic Fluid Filter Clog Detector NEW

Hydraulic tank pressure sensor monitors the pressure difference between the return line and tank inside pressure to determine the degree of clogging. If the difference exceeds a predetermined level, a warning appears on the multi-display, so any contamination can be trapped by the filter and replaced before it reaches the hydraulic fluid in the tank.

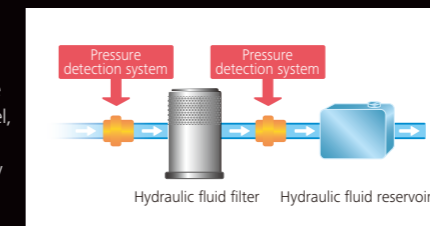



# Evolution Continues, with Improved Fuel Efficiency.

**14%\***  
Higher fuel saving means "Efficiency"

The new arm interflow system more efficiently controls hydraulic fluid flow, and significant reduction of in-line resistance and pressure loss boosts fuel efficiency by about 14%\*.

\* Compared to H-mode on the SK480LC-8



## Get More Done Faster with Superior Operability

### ME 2.6 m arm

■ Max. Bucket Digging Force	■ Max digging reach:
Normal: <b>282kN</b>	<b>11,250mm</b>
With power boost: <b>308kN</b>	■ Max digging depth: <b>6,820mm</b>
■ Max. Arm Digging Force	■ Max vertical digging depth: <b>6,110mm</b>
Normal: <b>239kN</b>	
With power boost: <b>261kN</b>	

### Short 3.0 m arm

■ Max. Bucket Digging Force	■ Max digging reach:
Normal: <b>270kN</b>	<b>11,770mm</b>
With power boost: <b>295kN</b>	■ Max digging depth: <b>7,360mm</b>
■ Max. Arm Digging Force	■ Max vertical digging depth: <b>6,670mm</b>
Normal: <b>224kN</b>	
With power boost: <b>245kN</b>	

Equipped with a 3.4m<sup>3</sup>\*2 ME bucket, the maximum digging reach stretches 370mm farther than the SK480LC-8, resulting in a reach of over 11m. **NEW**

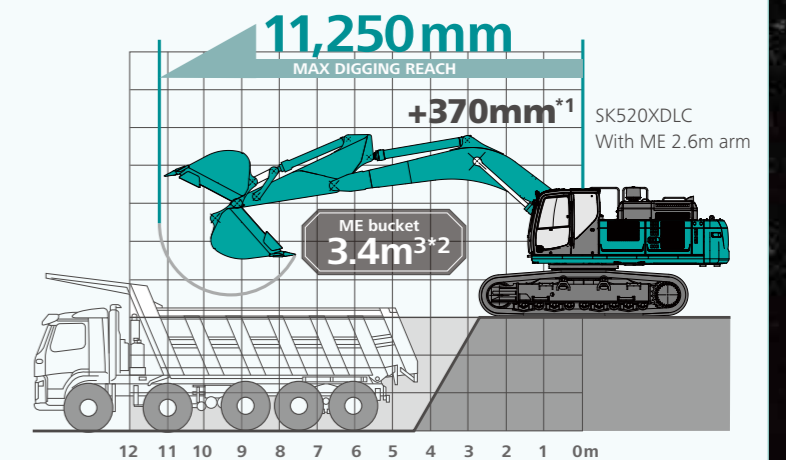

\*1 Compared to SK480LC-8.  
\*2 To minimize spillage, 3.1m<sup>3</sup> bucket may be better suited to width of some dump trucks.

## Hydraulic System: Revolutionary Technology Saves Fuel

### Arm Interflow System **NEW**

When lowering the boom, this system uses the downward force generated by the boom's weight to push fluid to the shovel arm. This greatly reduces the need to apply power from outside the system.

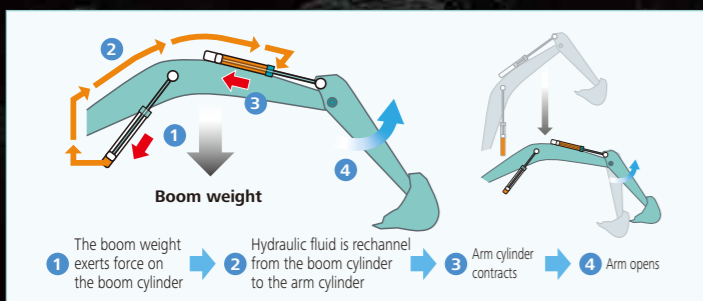

## Energy saving system saves fuel further

### Fuel efficient work mode ECO mode **NEW**

The fuel-saving ECO mode is newly provided to the work mode, selectable according to a desired operation. Fuel consumption can be greatly reduced.

- E** Used to reduce fuel consumption for small workloads  
**ECO-mode, 23% decrease**  
(compared to S-mode on the SK480LC-8)
- H** Used to prioritize the amount of work done  
**H mode, 14% decrease**  
(compared to H-mode on the SK480LC-8)
- S** Used to strike a balance between workloads and fuel efficiency  
**S mode, 13% decrease**  
(compared to S-mode on the SK480LC-8)

## Top Class Traveling Force

Powerful traveling force and drawbar pulling force deliver plenty of speed when climbing slopes or negotiating bad roads, and the agility to change direction swiftly and smoothly.

■ Drawbar Pulling Force: **415kN**

## EGR Cooler Reduces NOx

Cooled exhaust gases from the EGR cooler are mixed with fresh air in the intake. The recirculated air lowers the combustion temperature which reduces NOx.

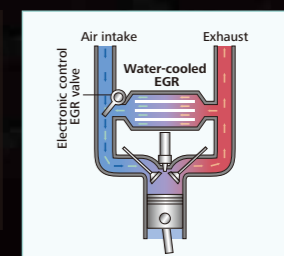



# Comfortable Cab Is Now Safer than Ever.

A work environment that is quieter and more comfortable. A cab that puts the operator first is key to improved safety.



## Large cab <sup>NEW</sup>

4 % larger than the previous cab capacity. Relaxing environment allows work to be performed in comfort.

## Air Conditioner <sup>NEW</sup> Louvers behind the Seat



The large air-conditioner has louvers on the back pillars that blow from behind and to the right and left of the operator's seat. They can be adjusted to put a direct flow of cool/warm air on the operator, which means a more comfortable operating environment.

## Super-Airtight Cab <sup>NEW</sup>



The high level of air-tightness keeps dust out of the cab.

## Low Vibration <sup>NEW</sup>

Coil springs absorb small vibrations, and high suspension mounts filled with silicone oil reduce heavy vibration. The long stroke achieved by this system provides excellent protection from vibration.

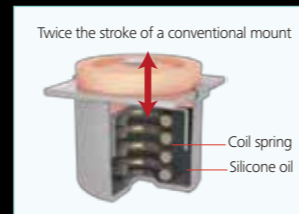

## Multi-Display in Color <sup>NEW</sup>

Brilliant colors and graphic displays are easy to recognize on the LCD multi-display in the console. The display shows fuel consumption, maintenance intervals, and more.



- 1 Analog gauge provides an intuitive reading of fuel level and engine water temperature
- 2 Green indicator light shows low fuel consumption during operation
- 3 Fuel consumption/Switch indicator for rear camera images
- 4 Digging mode switch
- 5 Monitor display switch

## One-Touch Attachment Mode Switch

A simple touch of a button, switches the hydraulic circuit and flow amount to match attachment changes. Icons help the operator to confirm the proper configuration at a glance.

## Comfort



## Broad View <sup>NEW</sup> Liberates the Operator

The front window features one large piece of glass without a center pillar on the right side for a wide, unobstructed view.

## Large Cab Is Easy <sup>NEW</sup> to Get in and Out of

The expanded cab provides plenty of room for a large door, more headroom and smoother entry and exit.



## More Comfortable Seat Means Higher Productivity



Vibration absorbing suspension seat



Seat recliner can be pushed back flat



Double slides allow adjustment for optimum comfort

## A Light Touch on the <sup>NEW</sup> Lever Means Smoother, Less Tiring Work



It takes 38% less effort to work the operation lever, which reduces fatigue over long working hours or continued operations.

## Interior Equipment Adds to Comfort and Convenience



24V outlet



Spacious storage tray



Large cup holder

## Safety

## ROPS Cab <sup>NEW</sup> (optional)



ROPS (Roll-Over-Protective Structure)-compliant cab clears ISO standards (ISO-12117-2: 2008) and ensures greater safety for the operator should the machine tip over.

## Wide view during operations High Visibility for Safety



Greater safety assured by rearview mirrors on left and right.

## Rear view camera <sup>NEW</sup> (optional)



Hammer for emergency exit



A rear view camera is installed as option to simplify checking for safety behind the machine. The picture appears on the color monitor.



# Efficient Maintenance Keeps the Machine in Peak Operating Condition.



Examples of displaying maintenance information

## Machine Information Display Function

- Displays only the maintenance information that's needed, when it's needed
- Self-diagnostic function provides early-warning detection and display of electrical system malfunctions
- Service-diagnostic function makes it easier to check the status of the machine
- Record function of previous breakdowns including irregular and transient malfunction

## Easy, On-the-Spot Maintenance

There is ample space in the engine compartment for a mechanic to do maintenance work inside. The distance between steps is lower so entry and exit is easier. And the mechanic can work in comfort, without contortions or unnatural body positions. Finally, the hood is lighter and easier to raise and lower.



Step/Hand rail

## Maintenance Work, Daily Checks, Etc., Can Be Done from Ground Level

The layout allows for easy access from the ground for many daily checks and regular maintenance tasks.

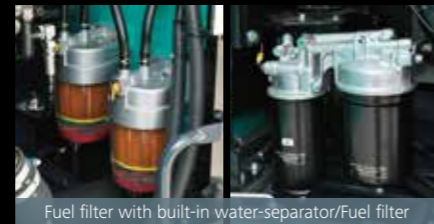

Fuel filter with built-in water-separator/Fuel filter



Left side

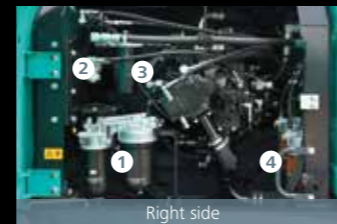

Right side

Simple layout for easy access to radiator and cooling system elements.

- 1 Engine oil filter
- 2 Pilot filter
- 3 Pump drain filter
- 4 Fuel filter with built-in water separator

## Easy Cleaning



Crawler frame



Detachable two-piece floor mat



Floor mat with raised edges



Engine oil pan



Double-element air cleaner

Special crawler frame design for easy mud removal cleaning.

Detachable two-piece floor mat with handles for easy removal. A floor drain is located under floor mat.

Floor mat's raised edges help keep the cab floor free of mud, simplify cleaning.

Engine oil pan equipped with drain valve.

## More Efficient Maintenance Inside the Cab

Internal and external air conditioner filters can be easily removed without tools for cleaning.



Air conditioner filters

## KOMEXS (Kobelco Monitoring Excavator System)

KOMEXS is the remote monitoring system for SK series excavators. When a hydraulic excavator is fitted with this system, data on the machine's operation, such as operating hours, location, fuel consumption, and maintenance status can be obtained remotely.



## Specifications

**SK500XD<sub>LC</sub>** SK500XDLC-10 **SK520XD<sub>LC</sub>** SK520XDLC-10

### Engine

Model	HINO P11C
Type	Water-cooled, 4cycle 6cylinder direct injection type diesel engine with intercooler turbo-charger
No. of cylinders	6
Bore and stroke	122 mm × 150 mm
Displacement	10.52 L
Rated power output	Net 257 kW/1,850 min <sup>-1</sup> (ISO 14396 : without fan)
Max. torque	Net 1,400 N·m/1,400 min <sup>-1</sup> (ISO 14396 : without fan)

### Hydraulic System

Pump	
Type	Two variable displacement pumps + One gear pump
Max. discharge flow	2 × 370 L/min
Relief valve setting	
Excavating circuits (main)	31.4 Mpa
Power boost	34.3 Mpa
Travel circuit	34.3 Mpa
Swing circuit	26.0 Mpa
Pilot control circuit	5.0 Mpa
Pilot control pump	Gear type
Main control valve	8-spool
Oil cooler	Air cooled type

### Swing System

Swing motor	Axial piston motor
Parking brake	Wet multiple plate, hydraulic operated automatically
Swing speed	7.6 min <sup>-1</sup>
Swing torque	183 kN·m

### Attachments

Backhoe bucket and combination

Use	Backhoe bucket					
	Heavy digging	Normal digging	Mass Excavating			
Bucket capacity	ISO heaped	m <sup>3</sup>	2.1	1.9	3.1	3.4
Struck		m <sup>3</sup>	1.5	1.5	2.2	2.45
Opening width	With side cutters	mm	1,660	1,750	1,850	1,990
	Without side cutters	mm	1,580	1,630	1,760	1,900
No. of teeth			5	5	5	6
Bucket weight		kg	2,270	1,560	2,280	2,410
Combination	3.0m short arm		○	○	—	—
	3.45m standard arm		○	○	—	—
	6.5m ME boom and 2.6 ME arm		—	—	○	○

◎ Standard ○ Recommend — Not applicable

### Travel System

Travel motors	Variable displacement piston pump
Travel brakes	Hydraulic
Parking brakes	Wet multiple plate
Travel shoes	50 each side
Travel speed (high/low)	5.4/3.4 km/h
Drawbar pulling force	415 kN
Gradeability	70 % (35 deg)

### Cab & Control

#### Cab

All-weather, sound-suppressed steel cab mounted on the high suspension mounts filled with silicone oil and equipped with a heavy, insulated floor mat.

#### Control

Two hand levers or two foot pedals for forward and backward operations of each track independently.

### Boom, Arm & Bucket

Boom cylinders	170 mm × 1,590 mm
Arm cylinder	190 mm × 1,970 mm
Bucket cylinder	SHD 160 mm × 1,410 mm
	ME 170 mm × 1,429 mm

### Refilling Capacities & Lubrications

Fuel tank	638 L
Cooling system	47.4 L
Engine oil	42.5 L
Travel reduction gear	2×15 L
Swing reduction gear	2×5 L
Hydraulic oil tank	371 L tank oil level
	631 L hydraulic system

**Working Ranges**

Unit: m

Boom	ME 6.5m		7.0 m	
	ME 2.6Arm	3.0Arm	3.45Arm	
Range				
a- Max. digging reach	11.25	11.77	12.07	
b- Max. digging reach at ground level	11.01	11.54	11.84	
c- Max. digging depth	6.82	7.36	7.81	
d- Max. digging height	11.15	11.16	10.94	
e- Max. dumping clearance	7.18	7.72	7.58	
f- Min. dumping clearance	3.07	3.23	2.78	
g- Max. vertical wall digging depth	6.11	6.67	7.12	
h- Min. swing radius	4.96	5.28	5.14	
i- Horizontal digging stroke at ground level	3.87	5.21	6.10	
j- Digging depth for 2.4 m (8') flat bottom	6.66	7.2	7.67	
Bucket capacity ISO heaped m <sup>3</sup>	3.4	2.1	1.9	

**Digging Force (ISO 6015)**

Unit: kN

Arm length	ME 2.6Arm	3.0Arm	3.45Arm
Bucket digging force	282/308*	270/295*	267/292*
Arm crowding force	239/261*	224/245*	203/222*

\*Power Boost engaged.

**Dimensions**

Unit: mm

Arm length	ME 2.6Arm	3.0Arm	3.45Arm
A Overall length	12,200	11,980	12,160
B Overall height (to top of boom)	4,330	3,800	3,610
C Overall width		3,550	
D Overall height (to top of cab)		3,320	
E Ground clearance of rear end*		1,260*	
F Ground clearance*		510*	
G Tail swing radius	SK500XDLC	3,800	
	SK520XDLC	3,880	
G' Distance from center of swing to rear end	SK500XDLC	3,800	
	SK520XDLC	3,880	
H Tumbler distance		4,400	
I Overall length of crawler		5,460	
J Track gauge		2,750	
K Shoe width		800	
L Overall width of upperstructure		3,110	

\*Without including height of shoe lug.

**Operating Weight & Ground Pressure**

In standard trim, with standard boom, 3.00 m arm, and 2.1 m<sup>3</sup> ISO heaped bucket

Shaped	Triple grouser shoes (even height)	
Shoe width	mm	600
Overall width of crawler	mm	3,350
Ground pressure	kPa	86
Operating weight	kg	49,900

In standard trim, with 6.5 m ME boom, 2.6 m ME arm, and 3.4 m<sup>3</sup> ISO heaped bucket

Shaped	Triple grouser shoes (even height)	
Shoe width	mm	600
Overall width of crawler	mm	3,350
Ground pressure	kPa	90
Operating weight	kg	52,200

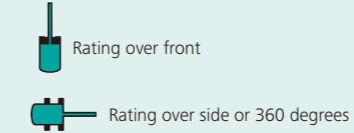
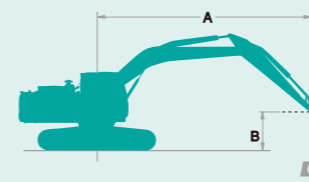
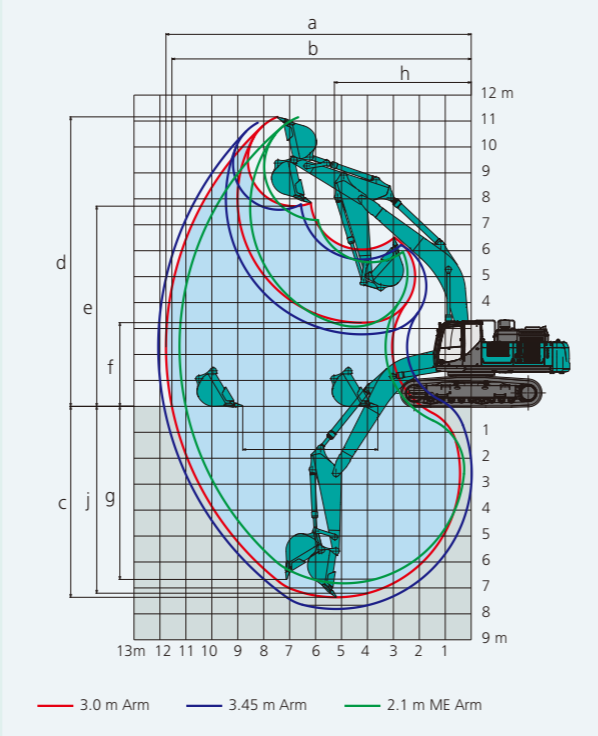

A: Reach from swing centerline to arm top  
 B: Arm top height above/below ground  
 C: Lifting capacities in Kilograms  
 Bucket: Without bucket  
 Relief valve setting: 34.3 MPa

SK500XDLC-10		Boom: 7.0 m Arm: 3.45 m Bucket: without Counterweight: 9,400 kg Shoe: HD 800 mm												
A		3.0 m		4.5 m		6.0 m		7.5 m		9.0 m		At Max. Reach		Radius
B		Rating over front	Rating over side or 360 degrees	Rating over front	Rating over side or 360 degrees	Rating over front	Rating over side or 360 degrees	Rating over front	Rating over side or 360 degrees	Rating over front	Rating over side or 360 degrees	Rating over front	Rating over side or 360 degrees	
9.0m	kg											*9,180	*9,180	7.76m
7.5m	kg											*8,990	8,650	8.86m
6.0m	kg							*9,490	*9,490	*9,000	8,360	*8,940	7,460	9.59m
4.5m	kg			*16,130	*16,130	*12,320	*12,320	*10,450	*10,450	*9,430	8,140	*9,020	6,780	10.04m
3.0m	kg			*20,340	*20,340	*14,360	14,080	*11,560	10,260	*10,030	7,860	*9,280	6,420	10.26m
1.5m	kg			*13,430	*13,430	*16,030	13,330	*12,580	9,820	*10,600	7,610	*9,530	6,310	10.25m
G.L.	kg			*16,440	*16,440	*16,970	12,890	*13,260	9,510	*10,980	7,430	*9,830	6,440	10.01m
-1.5m	kg	*11,830	*11,830	*22,960	19,530	*17,110	12,740	*13,450	9,380	*10,950	7,370	*10,150	6,860	9.53m
-3.0m	kg	*20,240	*20,240	*21,500	19,760	*16,400	12,810	*12,910	9,430			*10,460	7,740	8.76m
-4.5m	kg	*25,000	*25,000	*18,790	*18,790	*14,500	13,120	*10,940	9,740			*10,600	9,550	7.62m

SK500XDLC-10		Boom: 7.0 m Arm: 3.0 m Bucket: without Counterweight: 9,400 kg Shoe: HD 800 mm												
A		3.0 m		4.5 m		6.0 m		7.5 m		9.0 m		At Max. Reach		Radius
B		Rating over front	Rating over side or 360 degrees	Rating over front	Rating over side or 360 degrees	Rating over front	Rating over side or 360 degrees	Rating over front	Rating over side or 360 degrees	Rating over front	Rating over side or 360 degrees	Rating over front	Rating over side or 360 degrees	
9.0m	kg											*9,990	*9,990	7.36m
7.5m	kg							*9,540	*9,540			*9,650	9,100	8.51m
6.0m	kg							*10,010	*10,010	*9,520	8,230	*9,560	7,790	9.27m
4.5m	kg			*17,470	*17,470	*12,990	*12,990	*10,910	10,630	*9,830	8,050	*9,610	7,060	9.74m
3.0m	kg					*14,930	13,830	*11,950	10,140	*10,340	7,800	*9,750	6,680	9.96m
1.5m	kg					*16,410	13,150	*12,860	9,730	*10,820	7,570	*9,950	6,580	9.95m
G.L.	kg			*12,370	*12,370	*17,100	12,810	*13,400	9,470	*11,080	7,430	*10,180	6,740	9.70m
-1.5m	kg	*9,270	*9,270	*21,700	19,580	*16,980	12,730	*13,390	9,390	*10,790	7,440	*10,400	7,250	9.20m
-3.0m	kg	*20,210	*20,210	*20,630	19,870	*15,970	12,870	*12,550	9,510			*10,530	8,280	8.41m
-4.5m	kg	*22,360	*22,360	*17,460	*17,460	*13,560	13,280					*10,320	*10,320	7.21m

SK520XDLC-10		ME Boom: 6.5 m ME Arm: 2.6 m Bucket: without Counterweight: 11,200 kg Shoe: HD 800 mm													
A		3.0 m		4.5 m		6.0 m		7.5 m		9.0 m		At Max. Reach		Radius	
B		Rating over front	Rating over side or 360 degrees	Rating over front	Rating over side or 360 degrees	Rating over front	Rating over side or 360 degrees	Rating over front	Rating over side or 360 degrees	Rating over front	Rating over side or 360 degrees	Rating over front	Rating over side or 360 degrees		
9.0m	kg											*11,200	*11,200	6.24m	
7.5m	kg							*11,040	*11,040			*9,740	*9,740	7.56m	
6.0m	kg							*11,890	*11,890	*10,860	*10,860		*9,060	*9,060	8.41m
4.5m	kg					*13,460	*13,460	*11,510	*11,510			*8,790	*8,790	8.93m	
3.0m	kg					*15,240	*15,240	*12,390	11,350	*10,930	8,740	*8,810	8,500	9.17m	
1.5m	kg					*16,600	14,840	*13,150	10,970	*11,160	8,580	*9,110	8,390	9.15m	
G.L.	kg					*17,150	14,520	*13,510	10,760			*9,760	8,680	8.88m	
-1.5m	kg			*22,070	*22,070	*16,770	14,480	*13,140	10,750			*10,940	9,490	8.34m	
-3.0m	kg	*25,340	*25,340	*19,650	*19,650	*15,150	14,730					*10,990	*10,990	7.45m	
-4.5m	kg			*14,980	*14,980							*9,830	*9,830	6.06m	

**Notes:**

- Do not attempt to lift or hold any load that is greater than these lift capacities at their specified lift point radius and heights. Weight of all accessories must be deducted from the above lift capacities.
- Lift capacities are based on machine standing on level, firm, and uniform ground. User must make allowance for job conditions such as soft or uneven ground, out of level conditions, side loads, sudden stopping of loads, hazardous conditions, experience of personnel, etc.
- Arm top defined as lift point.
- The above lifting capacities are in compliance with ISO 10567. They do not exceed 87% of hydraulic lifting capacity or 75% of tipping load. Lifting capacities marked with an asterisk (\*) are limited by hydraulic capacity rather than tipping load.
- Operator should be fully acquainted with the Operator's and Maintenance Instructions before operating this machine. Rules for safe operation of equipment should be adhered to at all times.
- Lift capacities apply to only machine as originally manufactured and normally equipped by KOBELCO CONSTRUCTION MACHINERY CO., LTD.