

## Telescopic Crawler Crane

# TK750GFS

Model : TK750G

Max. Lifting Capacity : **75 t x 3.0 m**

Telescopic Boom Length : **10.0 m to 30.1 m**

Comply with Japanese Construction Codes for Mobile Cranes

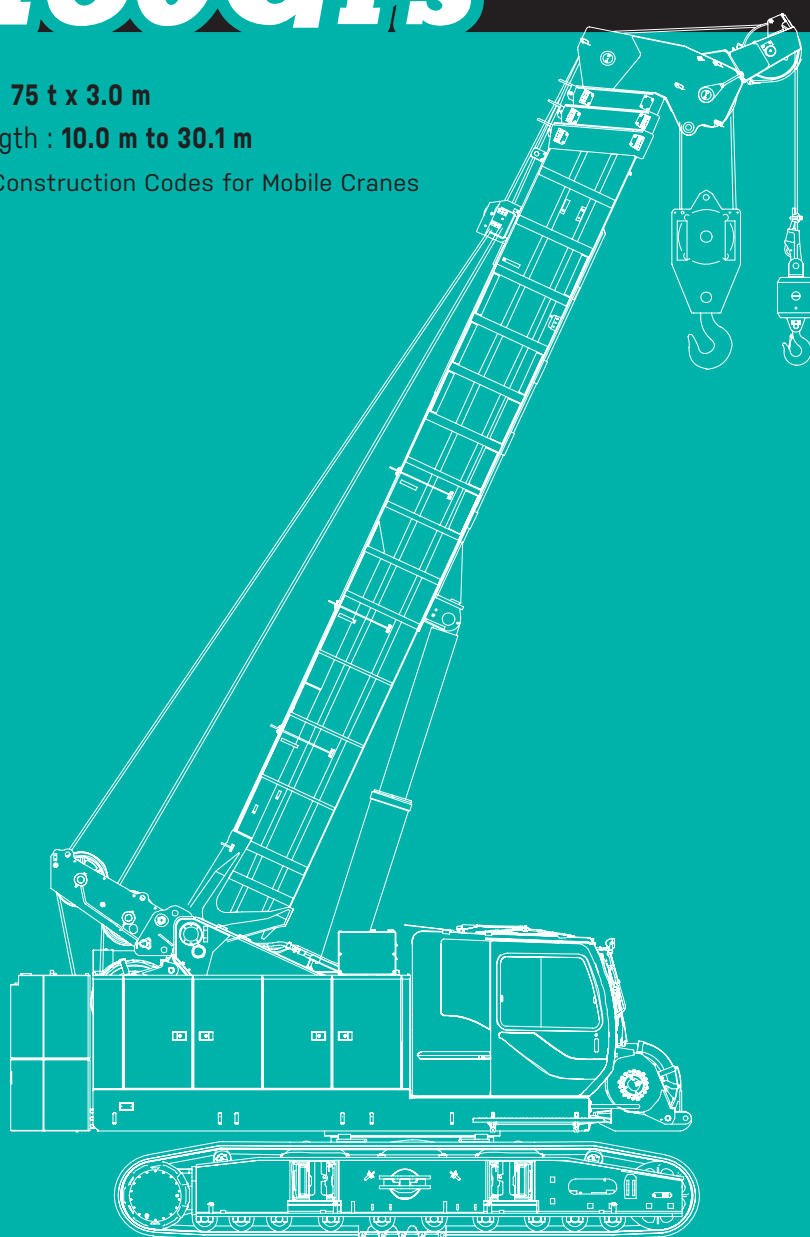

# KOBELCO



# TK750GFS CONTENTS

**3** SPECIFICATIONS

**5** GENERAL DIMENSIONS

**6** WORKING RANGES

**7** SUPPLEMENTAL DATA

**8** LIFTING CAPACITIES

**10** TRANSPORTATION PLAN

**11** PARTS AND ATTACHMENTS

**13** SELF-REMOVAL DEVICE

# SPECIFICATIONS



## Power Plant

**Model:** Daimler OM936LA (MTU 6R1000)  
**Type:** Water cooled 4 cycle, 6 cylinder, direct injection diesel with turbocharger, intercooler  
Complies with NRMM (Europe) Stage IV and US EPA Tier 4 Final  
**Displacement:** 7.697 L  
**Rated power:** 254 kW/2,000 min<sup>-1</sup>  
**Max. torque:** 1,245 N·m/1,400 min<sup>-1</sup>  
**Cooling system:** Water-cooled  
**Starter:** 24 V-3.9 kW  
**Radiator:** Corrugated type core, thermostatically controlled  
**Air cleaner:** Dry type with replaceable paper element  
**Throttle:** Twist grip type hand throttle, electrically actuated  
**Fuel filter:** Replaceable paper element  
**Batteries:** Two 12 V x 136 Ah/5 HR capacity batteries, series connected  
**Fuel tank capacity:** 400 L  
**AdBlue tank capacity:** 40 L



## Hydraulic System

**Main pumps:** 4-pumps (2 variable plunger pumps + 2 gear pumps) + 4-pumps (2 variable plunger pumps + 2 gear pumps)  
**Control:** Full-flow hydraulic control system for infinitely variable pressure to all winches, propel and swing. Controls respond instantly to the touch, delivering smooth function operation.  
**Cooling:** Oil-to-air heat exchanger (plate-fin type)  
**Filtration:** Full-flow and bypass type with replaceable element  
**Max. relief valve pressure:**  
**Load hoist, boom hoist and propel system:** 31.9 MPa  
**Swing system (free):** 27.4 MPa  
**Swing system (brake):** 24.5 MPa  
**Control system:** 6.6 MPa  
**2nd/3rd boom telescope (extend):** 20.6 MPa  
**2nd/3rd boom telescope (retract):** 20.6 MPa  
**Top boom telescope (extend):** 16.7 MPa  
**Top boom telescope (retract):** 20.6 MPa  
**Boom hoist (lower):** 9.5 MPa  
**Boom hoist (raise):** 27.4 MPa  
**Oil Quantity (at the reference level):** 791 L



## Load Hoisting System

Hydraulic motor drive with spur gear reduction with auto-brake, independent 2 winches, with free-fall function, third winch  
**Negative brake:** A spring-set, hydraulically released multiple-disk brake is mounted on the hoist motor and operated through a counter-balance valve. (Positive free fall brake is standard)  
**Drum lock:** External ratchet for locking drum  
**Drums:**  
**Main drum:** 614 mm P.C.D x 560 mm wide drum, grooved for 26 mm wire rope. Rope capacity is 110 m working length and 170 m storage length.

**Aux. drum:** 614 mm P.C.D x 560 mm wide drum, grooved for 26 mm wire rope. Rope capacity is 110 m working length and 170 m storage length.

**Third drum:** 614 mm P.C.D x 560 mm wide drum, grooved for 26 mm wire rope. Rope capacity is 125 m working length and 170 m storage length.

### Diameter of wire rope

**Main winch:** 26 mm x 110 m

**Aux. winch:** 26 mm x 110 m

**Third winch:** 26 mm x 125 m

### Line speed\*:

**Hoisting / lowering:** 124.5 to 32.7 m/min

### Line pull:

**Max. line pull\*:** 208.1 kN {21.2 tf}  
(Referential performance)

**Rated line pull:** 107.9 kN {11.0 tf}

\*Single line on first drum layer



## Swing System

Swing unit is powered by hydraulic motor driving spur gears through planetary reducer, the swing system provides 360° rotation.

**Swing parking brakes:** A spring-set, hydraulically released multiple-disk brake is mounted on swing motor.

**Swing circle:** Single-row ball bearing with an integral internally cut swing gear.

**Swing lock:** Manually, four position lock for transportation

**Swing speed:** 2.5 min<sup>-1</sup>



## Upper Structure

Torsion-free precision machined upper frame. All components are located clearly and service friendly. Engine will with low noise level.

**Counterweight:** 17.2 ton



## Cab & Control

Totally enclosed, full vision cab with safety glass, fully adjustable, high backed seat with a headrest and armrests, and intermittent wiper and window washer (skylight and front window).

### Cab fittings:

Air conditioner, convenient compartment (for tool), cup holder, cigarette lighter, sun visor, roof blind, tinted glass, floor mat, footrest, and shoe tray.



## Lower Structure

Steel-welded carbody with axles. Crawler assemblies can be hydraulically extended for wide-track operation or retracted for transportation. Crawler belt tension is maintained by hydraulic jack force on the track-adjusting bearing block.

**Crawler drive:** Independent hydraulic propel drive is built into each crawler side frame. Each drive consists of a hydraulic

motor propelling a driving tumbler through a planetary gear box. Hydraulic motor and gear box are built into the crawler side frame within the shoe width.

**Crawler brakes:** Spring-set, hydraulically released parking brakes are built into each propel drive.

**Steering mechanism:** A hydraulic propel system provides both skid steering (driving one track only) and counter-rotating steering (driving each track in opposite directions).

**Track rollers:** Sealed track rollers for maintenance-free operation.

**Shoe (flat):** 800 mm wide each crawler

**Max. gradeability:** 40%



## Weight

Including upper and lower machine, 17.2 ton counterweight, boom, hook, and other accessories.

**Weight:** 73.5 ton

**Ground pressure:** 87.8 kPa



## Attachment

### Boom:

Four section, box construction, 2<sup>nd</sup> and 3<sup>rd</sup> simultaneously telescoping, 4<sup>th</sup> independently telescoping.

### Boom length

	Min. Length	Max. Length
Telescopic Boom	10.0 m	30.1 m

## Main Specifications (Model: TK750G)

Crane Performance		
Max. Rated Load	10.0 m boom	75.0 t x 3.0 m (8-lines)
	16.7 m boom	36.0 t x 4.5 m (4-lines)
	23.4 m boom	29.0 t x 6.0 m (3-lines)
	30.1 m boom	18.5 t x 8.0 m (2-lines)
	Aux. sheave (Max.)	11.0 t (1-line)
Main Boom Length	10.0 m to 30.1 m	
Main Hook Max. Height	30.4 m	
Main Hook Max. Operating Radius	27.8 m	
Winch (Main / Aux. / Third*1)		
Max. Line Speed (1st layer)	125 m/min	
Rated Line Pull (Single line)	107.9 kN {11.0 tf}	
Max. Line Pull (Referential performance)	208.1 kN {21.2 tf}	
Wire Rope Diameter	26 mm	
Wire Rope Length	110 m (Main), 110 m (Aux.), 125 m (Third *1)	
Brake Type (Free fall)	Wet-type multiple disc brake	
Working Speed		
Swing Speed	2.5 min <sup>-1</sup> {2.5 rpm}	
Travel Speed	1.7 / 1.2 (High / Low select) km/h	
Boom Telescoping Speed	125 sec / 20.1 m	
Boom Raising Speed	64 sec / 0 to 83 degree	

Power Plant	
Model	Daimler OM936LA (MTU 6R1000)
Engine Output	254 kW / 2,000 min <sup>-1</sup>
Fuel Tank	400 L
AdBlue Tank	40 L
Hydraulic System	
Main Pumps	4 pumps (2 variable plunger pumps + 2 gear pumps) + 4 pumps (2 variable plunger pumps + 2 gear pumps)
Max. Pressure	31.9 MPa {325 kgf/cm <sup>2</sup> }
Oil Quantity (at the reference level)	791 L
Self-Removal Device	
	Counterweight / Crawler (Option)
Weight	
Operating Weight	73.5 t
Ground Pressure	87.8 kPa {0.90 kgf/cm <sup>2</sup> }
Counterweight	17,200 kg
Transport Weight	29,600 kg (31,500 kg *2)

\*1 Third winch is optional

\*2 With optional parts and attachments

# GENERAL DIMENSIONS

## Counterweight Self-Removal Device Extended

(Unit: mm)

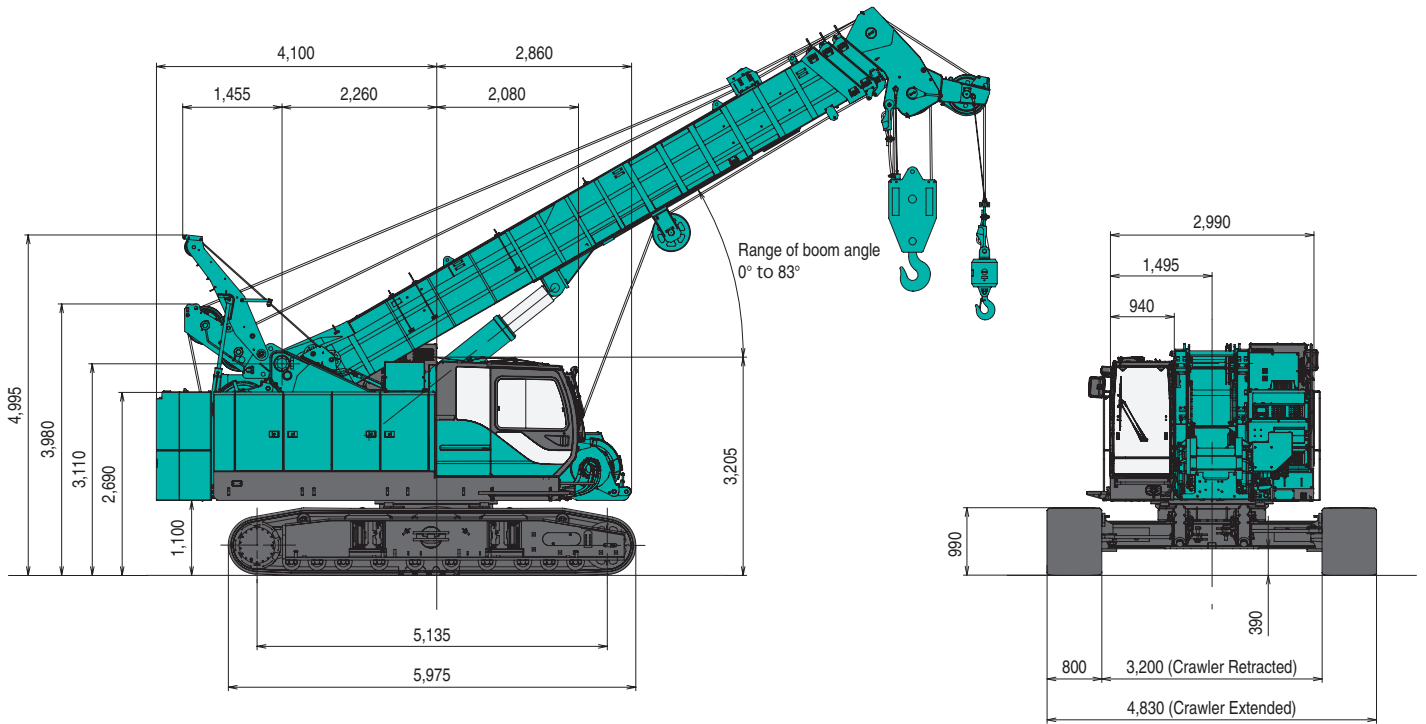

## Limit of Hook Lifting

### Boom Horizontal

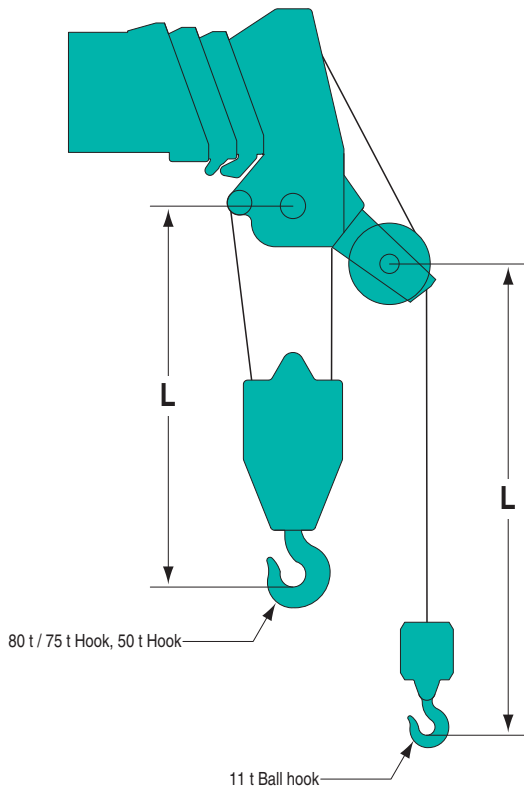

### Boom at Maximum Angle

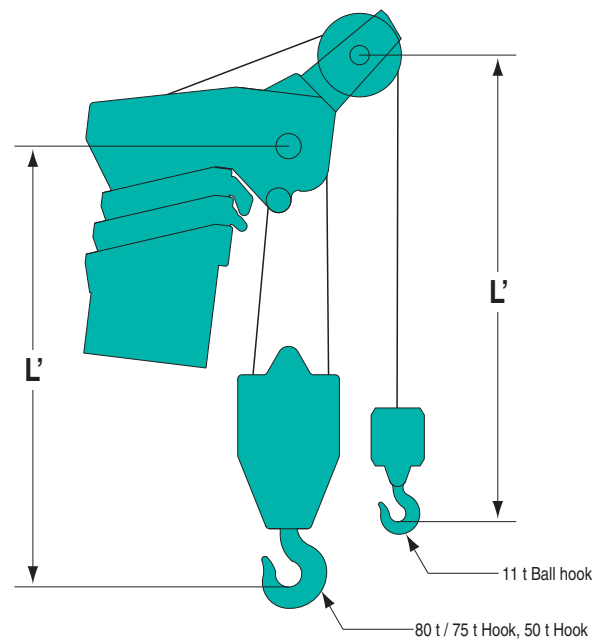

Hook	L	L'
80 t / 75 t	2,690 mm	3,033 mm
50 t	2,587 mm	2,931 mm
11 t Ball hook	3,327 mm	3,211 mm

# WORKING RANGES

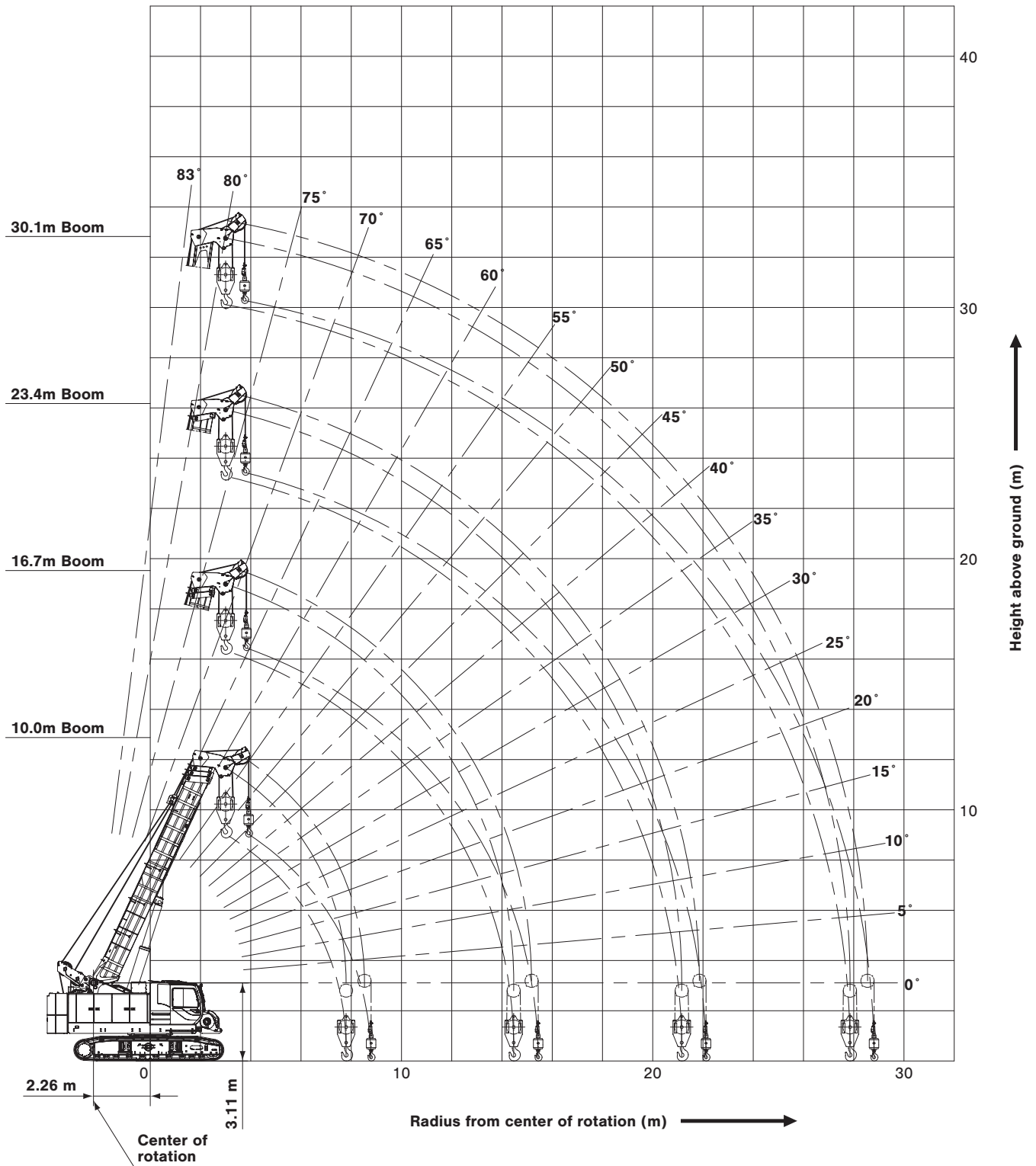

# SUPPLEMENTAL DATA

1. Ratings according to Japanese construction codes for mobile cranes.

The crane rated loads are including the weight of hooks and other lifting gears.

Values marked with  are decided according to strength of the machine.

Other values are decided according to stability of the machine.

Type of hook	75 t	50 t	50 t (Single hook)	32 t	11 t
Weight	950 kg	860 kg	850 kg	550 kg	300 kg

## CAUTION

**When uses of the lightweight hook (option), it may not be lowered depending on the boom length, boom angle and/or the hook height.**

**In case of the hook is not lowered, add the suitable weights adjusted up to the weight of the ball hook.**

2. Even when it is intended to lift a crane rated load, the operator shall be responsible for ensuring safety depending on the actual condition such as reducing of the load and reduction of a working speed, if applicable conditions such as the influence of wind, ground condition, working speed and others are likely to cause safety problems.

3. A working radius shall mean a horizontal distance from the center line of center of rotation of the crane to the center of gravity of the load to be lifted.

The working radius is based on an actual value with the factor of deflection of the boom taken into considerations.

Thus, be sure to conduct the crane work while referencing the working radius.

4. Be sure to keep the crawler frame extended up to the specified position during execution of the crane work.

5. The auxiliary sheave ratings are determined by deducting the weight of the main hook from the main boom ratings at the same operating radii.

The maximum auxiliary sheave rating is 11,000 kg.

6. Where no value is given in the columns of the crane rated loads chart, no execution of work is allowed.

(If the boom should be inclined to an angle smaller than the min. boom angle, be fully careful, since the basic machine may overturn with no load.)

7. The minimum number of parts line of the main hook in the main winch lifting is decided within a range not to exceed the value of 11,000 kg per single wire rope.

The standard numbers of parts line by boom length are as shown below.

Boom length : m	10.0	16.7	23.4	30.1
Hook : t	75		50 / 32	
Number of parts line	8	4	3	2

8. The minimum number of part lines of the main hook in the third drum winch lifting is decided within a range not to exceed the value of 11,000 kg per single wire rope.

The standard numbers of parts line by boom length are as shown below.

Boom length : m	10.0	16.7	23.4	30.1
Hook : t	75		50 / 32	
Number of parts line	8	4	3	2

9. To prevent a load being lifted and carried from falling due to wrong operation or others, do not perform a free fall work in the crane work.



# LIFTING CAPACITIES



## Rated Crane Load Table

Counterweight: 17.2 t  
Crawler is fully extended

(Unit: metric ton)

Working radius (m)	Boom length (m)					Boom length (m)	Working radius (m)
		10.0	16.7	23.4	30.1		
3.0		75.0	36.0	29.0	18.5	3.0	
3.5		60.0	36.0	29.0	18.5	3.5	
3.7		56.0	36.0	29.0	18.5	3.7	
4.0		51.0	36.0	29.0	18.5	4.0	
4.5		44.5	36.0	29.0	18.5	4.5	
5.0		39.5	35.0	29.0	18.5	5.0	
5.5		36.0	33.0	29.0	18.5	5.5	
6.0		34.4	30.7	29.0	18.5	6.0	
6.5		31.4	29.8	26.1	18.5	6.5	
7.0		28.9	27.2	23.2	18.5	7.0	
7.5		26.3	25.1	21.6	18.5	7.5	
7.7		25.1	24.4	20.9	18.5	7.7	
8.0			23.3	20.0	18.5	8.0	
8.5			21.2	19.0	17.0	8.5	
9.0			19.4	18.1	15.5	9.0	
9.5			17.9	17.0	14.5	9.5	
10.0			16.5	16.3	13.5	10.0	
11.0			14.2	14.1	12.8	11.0	
12.0			12.4	12.3	11.8	12.0	
13.0			11.0	10.8	11.0	13.0	
14.0			9.7	9.5	9.9	14.0	
14.4			9.3	9.1	9.5	14.4	
15.0				8.5	9.0	15.0	
16.0				7.6	8.2	16.0	
17.0				6.6	7.4	17.0	
18.0				6.2	6.7	18.0	
19.0				5.6	6.1	19.0	
20.0				5.0	5.5	20.0	
21.0				4.6	5.1	21.0	
21.1				4.5	5.0	21.1	
22.0					4.6	22.0	
23.0					4.2	23.0	
24.0					3.9	24.0	
25.0					3.5	25.0	
26.0					3.2	26.0	
27.0					2.9	27.0	
27.8					2.7	27.8	
Max. boom angle		65°	76°	80°	82°	Max. boom angle	
Min. boom angle		0°	0°	0°	0°	Min. boom angle	

Note:

Ratings shown in   are determined by the strength of the boom or other structural components.

# LIFTING CAPACITIES



## Rated Crane Load Table

Counterweight: 8.2 t (Option)  
Special type boom rated load

(Unit: metric ton)

Working radius (m)	Boom length (m)					Working radius (m)
		10.0	16.7	23.4	30.1	
3.0		75.0	36.0	29.0	18.5	3.0
3.5		60.0	36.0	29.0	18.5	3.5
3.7		56.0	36.0	29.0	18.5	3.7
4.0		51.0	36.0	29.0	18.5	4.0
4.5		44.5	36.0	29.0	18.5	4.5
5.0		37.2	35.0	29.0	18.5	5.0
5.5		31.3	30.9	29.0	18.5	5.5
6.0		26.9	26.5	26.3	18.5	6.0
6.5		23.5	23.1	22.9	18.5	6.5
7.0		20.8	20.4	20.1	18.5	7.0
7.5		18.6	18.1	17.9	18.5	7.5
7.7		17.8	17.4	17.2	18.5	7.7
8.0			16.3	16.1	16.8	8.0
8.5			14.8	14.5	15.2	8.5
9.0			13.4	13.2	13.8	9.0
9.5			12.3	12.0	12.7	9.5
10.0			11.2	11.0	11.7	10.0
11.0			9.6	9.3	10.0	11.0
12.0			8.2	8.0	8.6	12.0
13.0			7.1	6.9	7.5	13.0
14.0			6.2	6.0	6.6	14.0
14.4			5.9	5.7	6.2	14.4
15.0				5.2	5.8	15.0
16.0				4.6	5.1	16.0
17.0				4.0	4.5	17.0
18.0				3.5	4.0	18.0
19.0				3.0	3.6	19.0
20.0				2.6	3.2	20.0
21.0				2.2	2.8	21.0
21.1				2.1	2.7	21.1
22.0					2.4	22.0
23.0					2.1	23.0
24.0					1.8	24.0
25.0					1.5	25.0
26.0					1.3	26.0
Max. boom angle		65°	76°	80°	82°	Max. boom angle
Min. boom angle		0°	0°	0°	22°	Min. boom angle

Note:

Ratings shown in   are determined by the strength of the boom or other structural components.



## Rated Crane Load Table

Without Counterweight (Option)  
Special type boom rated load

(Unit: metric ton)

Working radius (m)	Boom length (m)			Working radius (m)
		10.0	16.7	
3.0		30.0	20.0	3.0
3.5		30.0	20.0	3.5
3.7		30.0	20.0	3.7
4.0		30.0	20.0	4.0
4.5		30.0	20.0	4.5
5.0		24.5	20.0	5.0
5.5		20.5	20.0	5.5
6.0		17.5	17.1	6.0
6.5		15.1	14.8	6.5
7.0		13.3	12.9	7.0
7.5		11.8	11.4	7.5
7.7		11.2	10.8	7.7
8.0			10.1	8.0
8.5			9.1	8.5
9.0			8.1	9.0
9.5			7.4	9.5
10.0			6.7	10.0
11.0			5.5	11.0
12.0			4.6	12.0
13.0			3.9	13.0
14.0			3.3	14.0
14.4			3.1	14.4
Max. boom angle		65°	76°	Max. boom angle
Min. boom angle		0°	0°	Min. boom angle

# TRANSPORTATION PLAN

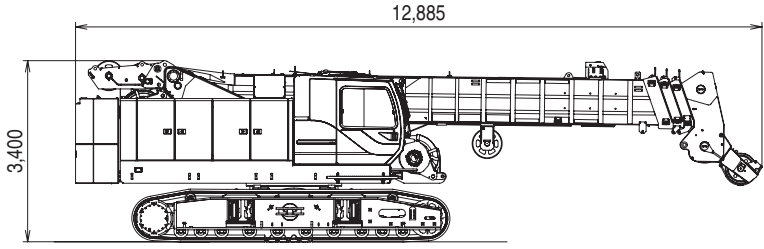
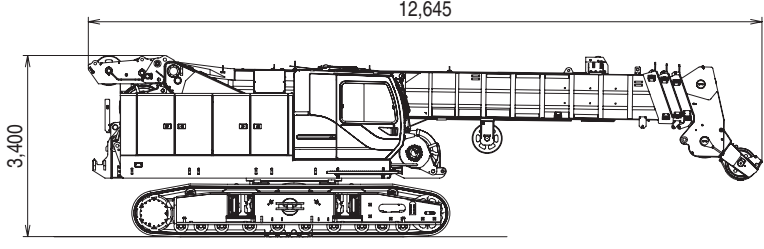
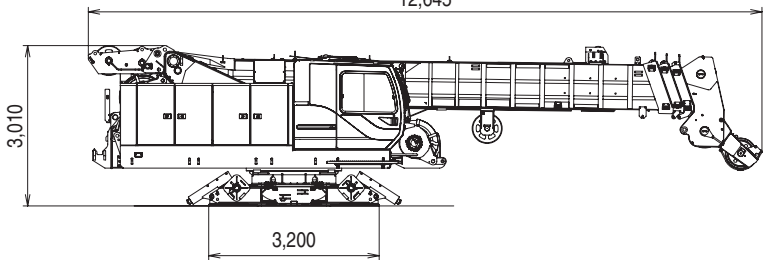
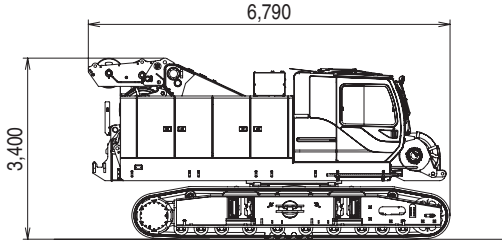
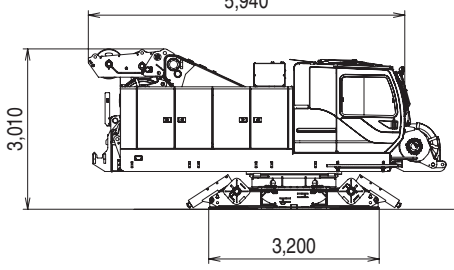
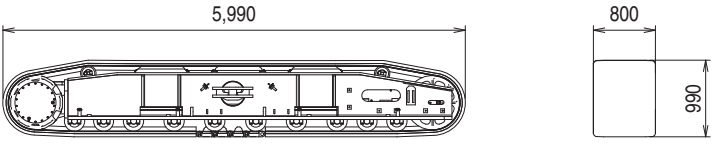
Name	Dimension (mm)	Weight (kg)
<b>Base Machine</b> with counterweight		72,300
<b>Base Machine</b> without counterweight		55,100
<b>Base Machine</b> without counterweight and crawler		40,100
<b>Base Machine</b> without counterweight and boom		44,800
<b>Base Machine</b> without counterweight, crawler and boom	 <p data-bbox="917 1668 1212 1736">Weight of boom raise cylinder is contained</p>	29,600
<b>Crawler</b>		7,500

# PARTS AND ATTACHMENTS

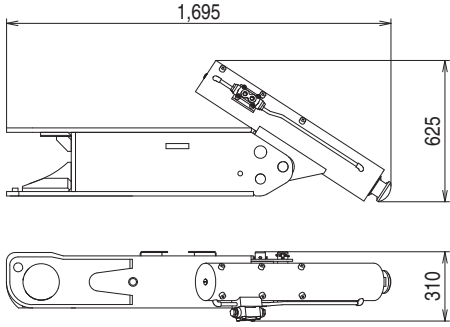
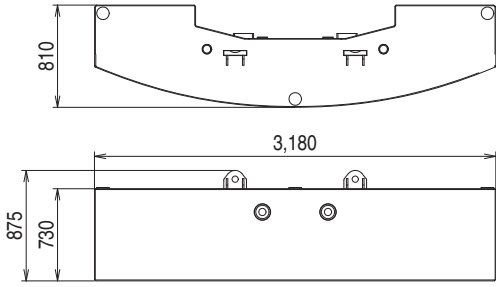
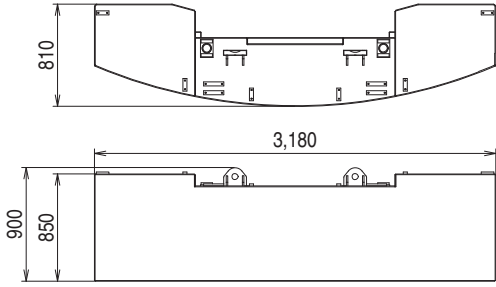
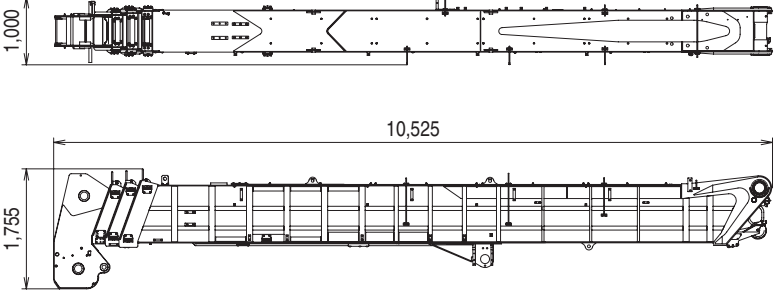
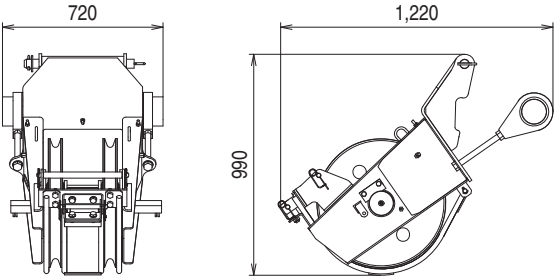
Name	Dimension (mm)	Weight (kg)
<b>Translifter</b>		345
<b>Counterweight (1)</b>		8,200
<b>Counterweight (2)</b>		9,000
<b>Boom Assy</b>		9,990
<b>Double Sheave Type Auxiliary Sheave</b>		300

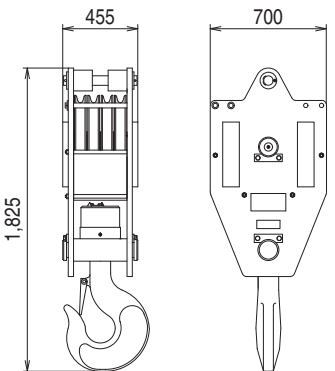
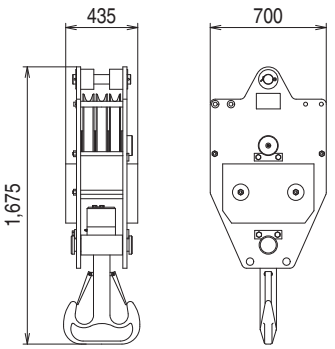
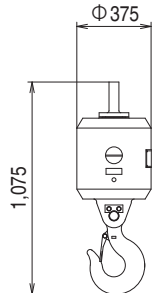
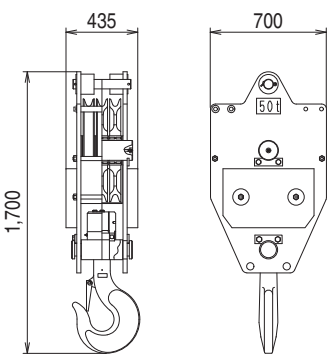
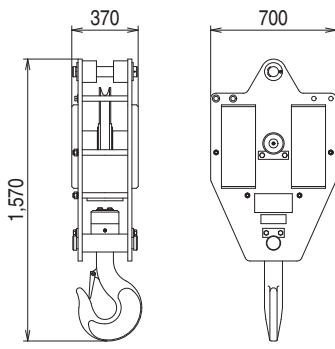
Name	Dimension (mm)	Weight (kg)
<b>75 t Hook (Single Hook)</b>		950
<b>50 t Hook (Double Hook)</b>		860
<b>11 t Ball Hook</b>		300
<b>50 t Hook (Single Hook) (Option)</b>		850
<b>32 t Hook (Single Hook) (Option)</b>		550

# SELF-REMOVAL DEVICE

## Counterweight (Option)

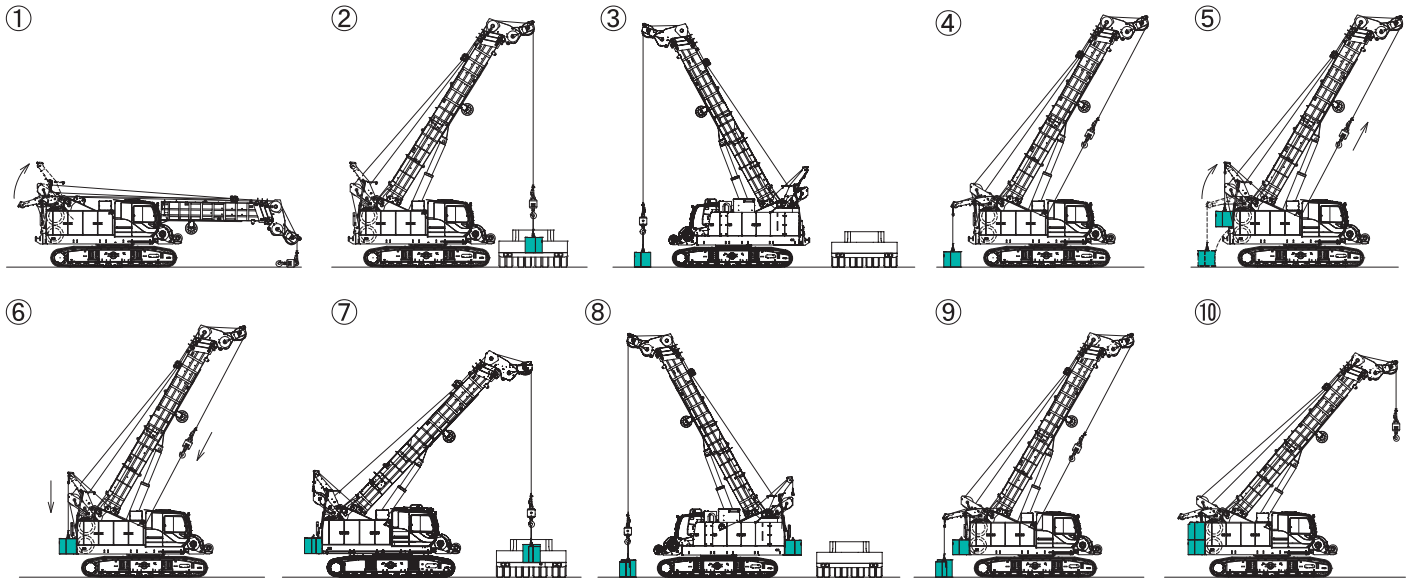

## Crawler (Option)

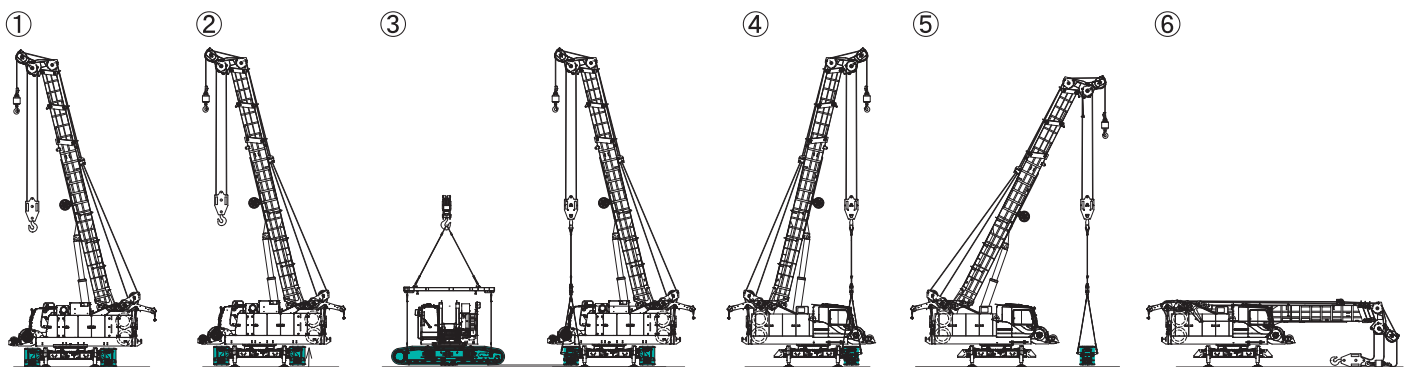

## Recommended Attachments

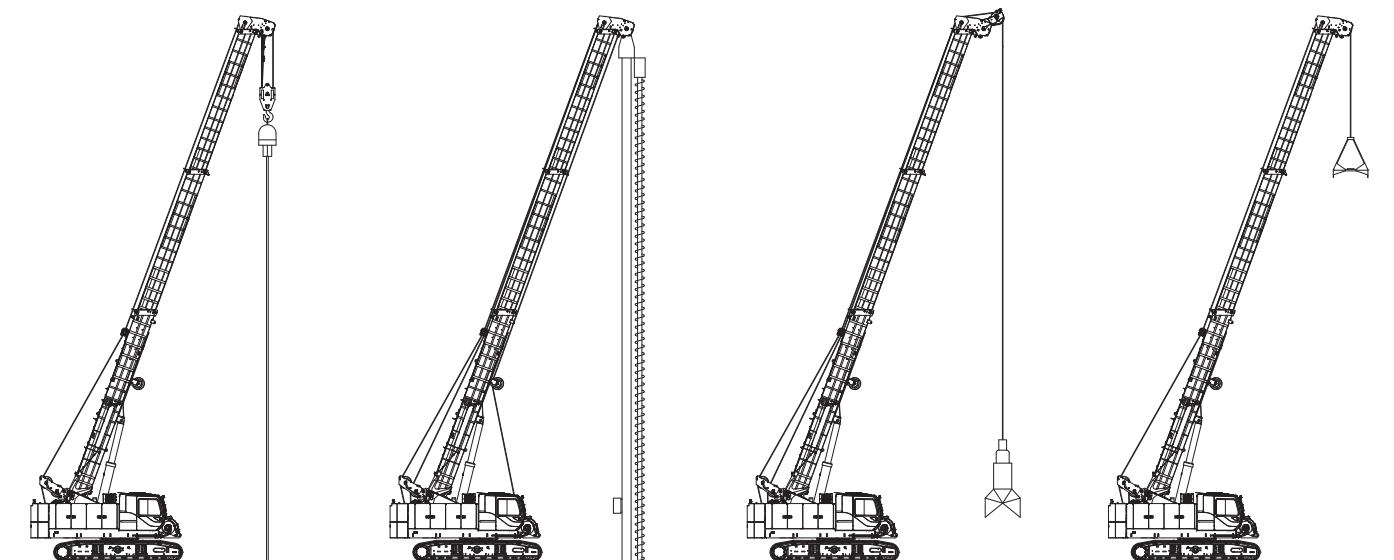

Vibro-hammer

Auger attachments

Electric type under 44.5kN/m  
Hydraulic type under 57.0kN/m

Hammer-grab

1,500dia. ○  
2,000dia. right weight ○  
2,000dia. heavy weight △

Clamshell

Total weight under 5.5 metric tons (2way)



Note: This catalog may contain photographs of machines with specifications, attachments and optional equipment not certified for operation in your country. Please consult KOBELCO for those items you may require. Due to our policy of continual product improvements all designs and specifications are subject to change without advance notice.

Copyright by KOBELCO CONSTRUCTION MACHINERY CO., LTD. No part of this catalog may be reproduced in any manner without notice.

## **KOBELCO CONSTRUCTION MACHINERY CO., LTD.**

Inquiries To:

5-15, Kitashinagawa 5-chome, Shinagawa-ku, Tokyo 141-8626 JAPAN

Tel: +81-3-5789-2121 Fax: +81-3-5789-3372

URL: <https://www.kobelcocm-global.com>