

# TK750FS

Model TK750

## TELESCOPIC CRAWLER CRANE

**Max. Lifting Capacity : 75t × 3.0m** Comply with Japanese Construction Codes for Mobile Cranes.

### ▣ GENERAL SPECIFICATION

Model		TK750		
<b>Weight</b>				
Operating weight		t	74.8	
Ground pressure		kPa{kgf/cm <sup>2</sup> }	89.4{0.91}	
<b>Crane Performance</b>				
Max. rated load	9.99m boom	t×m	75.0×3.0 (8-lines)	
	16.7m boom	t×m	36.0×4.5 (4-lines)	
	23.4m boom	t×m	29.0×6.0 (3-lines)	
	30.1m boom	t×m	18.5×8.0 (2-lines)	
	Aux. sheave (max.)	t×m	11.0 (1-line)	
Main boom length		m	9.99~30.1	
Main hook max. height		m	30.4	
Main hook max. operating radius		m	27.8	
Line speed	Main	m/min	125 (at 1st layer)	
	Aux.	m/min	125 (at 1st layer)	
	Third	m/min	125 (at 1st layer)	
Rated line pull	Main	kN{tf}	107.9{11.0}	
	Aux.	kN{tf}	107.9{11.0}	
	Third	kN{tf}	107.9{11.0}	
Max. line pull (Referential performance)	Main	kN{tf}	208{21.2}	
	Aux.	kN{tf}	208{21.2}	
	Third	kN{tf}	208{21.2}	
Boom telescoping speed		sec/m	125/20.1	
Boom raising speed		sec/degree	64/0~83	
Swing speed		min <sup>-1</sup> {rpm}	2.5{2.5}	
<b>Boom Structure</b>				
Main boom		Four section, box construction, 2nd and 3rd simultaneously telescoping, 4th independently telescoping		
Boom hoist device		Direct forced type by double acting hydraulic cylinder (one)		
Boom telescoping device		Direct forced type by double acting hydraulic cylinder (three)		
Load hoist device		Hydraulic motor drive with spur gear reduction with auto-brake, independent 2 winches, with free-fall function, third winch		
Swing device		Hydraulic drive motor with planetary gear reduction with hand brake, swing neutral-free or neutral-brake selector type		
<b>Wire Rope</b>				
Main winch		mm×m	26dia.×110 IWRC6×Fi (29) anti twist rope	
Aux. winch		mm×m	26dia.×110 IWRC6×Fi (29) anti twist rope	
Third winch		mm×m	26dia.×125 IWRC6×Fi (29) anti twist rope	
<b>Hydraulic Device</b>				
Hydraulic oil tank		ℓ	860	
<b>Upper Structure</b>				
Engine	Model		MITSUBISHI 6D24-TLE2A	
	Type		Water cooled, 4 cycle, 6 cyls, direct injection diesel with turbocharger, intercooler	
	Total displacement		ℓ	11.945
	Max. output		kW/min <sup>-1</sup> {PS/rpm}	235/2,000{320/2,000}
	Max. torque		N·m/min <sup>-1</sup> {kgf·m/rpm}	1,245/1,400{127/1,400}
Fuel tank		ℓ	400	
<b>Lower Structure</b>				
Propel system		Hydraulic motors, planetary reducer, direct drive, shoe-in-type		
Travel speed		km/h	1.9/1.2	
Gradeability		%	40	

Units are SI units. { } indicates conventional units.

# KOBELCO

## ► LIFTING CAPACITY

### ► Note

(1) Rated load do not exceed 78% of the tipping loads with machine set horizontally on a firm and level ground, safety the specified stability over the front, and include weight of hook block (s) and other handling accessories.

Ratings shown in  are based on the machine's structural strength, and others are determined by the machine's stability.

Hooks	75-ton	50-ton	32-ton	11-ton	11-ton (light)
Weight	950kg	860kg	550kg	300kg	100kg

Note : 11-ton light swivel ball hook is option.

(2) Rated loads shown are based on freely suspended loads and make no allowance for such factors as wind effect on lifted load, ground conditions out-of-level. Operating speeds or any other condition that could be detrimental to the safe operation of this equipment, the operator, therefore, has the responsibility to judge the existing conditions and reduce lifted loads and operating speeds accordingly.

(3) Operating radius is the horizontal distance from centerline of rotation to a vertical line through the center of gravity of the load. Operating radius given in the charts allow for loaded boom deflection and reduce lifted loads and operating speeds accordingly.

(4) Both crawlers should be fully extended.

(5) The ratings of the auxiliary sheave are the same as the main boom ratings, but should not exceed 11,000kg. Ratings of the auxiliary sheave are calculated by deducting from the main boom ratings 75 ton hook weight (950kg) with the main boom extended ranging from 9.99m to 16.7m, and 50 ton hook weight (860kg) with the main boom extended over 16.7m up to its maximum length.

(6) The main boom ratings shall be applied to the third drum ratings, but the jib ratings shall not exceed 11,000kg.

(7) To determine load ratings that fall between those shown in the charts, proceed as follows :

- a) For boom lengths not listed use rating for next longer boom length or next shorter boom length, whichever is smaller.
- b) For load radii not shown, use rating for next larger radius.

(8) At radii and boom lengths where no ratings are shown on chart, operation is not intended nor approved.

(9) Standard hoist reevings are shown below. Rated single-line pull must not exceed 11,000kg.

Boom length	9.99m	16.7m	23.4m	30.1m
Hook	75-ton		50-ton/32-ton	
No. of reeving	8	4	3	2

(10) Third drum hoist reevings are shown below. Rated single-line pull must not exceed 11,000kg.

Boom length	9.99m	16.7m	23.4m	30.1m
Hook	75-ton		50-ton/32-ton	
No. of reeving	8	4	3	2

(11) In order to prevent a load from falling down to mistake of operation, do not use free-fall in crane operation.

## ► With 17.2 ton counterweight

(Unit : metric ton)

Working radius (m)	Boom length (m)				Working radius (m)
	9.99	16.7	23.4	30.1	
3.0	75.00	36.00	29.00	18.50	3.0
3.5	60.00	36.00	29.00	18.50	3.5
3.7	56.00	36.00	29.00	18.50	3.7
4.0	51.00	36.00	29.00	18.50	4.0
4.5	44.50	36.00	29.00	18.50	4.5
5.0	39.50	35.00	29.00	18.50	5.0
5.5	36.00	33.00	29.00	18.50	5.5
6.0	34.40	30.70	29.00	18.50	6.0
6.5	31.40	29.80	26.10	18.50	6.5
7.0	28.90	27.20	23.20	18.50	7.0
7.5	26.30	25.10	21.60	18.50	7.5
7.7	25.10	24.40	20.90	18.50	7.7
8.0		23.30	20.00	18.50	8.0
8.5		21.20	19.00	17.00	8.5
9.0		19.40	18.10	15.50	9.0
9.5		17.90	17.00	14.50	9.5
10.0		16.50	16.30	13.50	10.0
11.0		14.20	14.10	12.80	11.0
12.0		12.40	12.30	11.80	12.0
13.0		11.00	10.80	11.00	13.0
14.0		9.70	9.50	9.90	14.0
14.4		9.30	9.10	9.50	14.4
15.0			8.50	9.00	15.0
16.0			7.60	8.20	16.0
17.0			6.60	7.40	17.0
18.0			6.20	6.70	18.0
19.0			5.60	6.10	19.0
20.0			5.00	5.50	20.0
21.0			4.60	5.10	21.0
21.1			4.50	5.00	21.1
22.0				4.60	22.0
23.0				4.20	23.0
24.0				3.90	24.0
25.0				3.50	25.0
26.0				3.20	26.0
27.0				2.90	27.0
27.8				2.70	27.8
Max. boom angle	65.0°	75.6°	79.8°	82.1°	Max. boom angle
Min. boom angle	0°	0°	0°	0°	Min. boom angle

Ratings shown in  are determined by the strength of the boom or other structural components.

▶ With 8.2 ton counterweight (optional setting)

(Unit : metric ton)

Working radius (m) \ Boom length (m)	9.99	16.7	23.4	30.1	Boom length (m) \ Working radius (m)
3.0	75.00	36.00	29.00	18.50	3.0
3.5	60.00	36.00	29.00	18.50	3.5
3.7	56.00	36.00	29.00	18.50	3.7
4.0	51.00	36.00	29.00	18.50	4.0
4.5	44.50	36.00	29.00	18.50	4.5
5.0	37.20	35.00	29.00	18.50	5.0
5.5	31.30	30.90	29.00	18.50	5.5
6.0	26.90	26.50	26.25	18.50	6.0
6.5	23.50	23.10	22.85	18.50	6.5
7.0	20.75	20.35	20.10	18.50	7.0
7.5	18.55	18.10	17.85	18.50	7.5
7.7	17.75	17.35	17.15	18.50	7.7
8.0		16.30	16.05	16.75	8.0
8.5		14.75	14.50	15.15	8.5
9.0		13.40	13.15	13.80	9.0
9.5		12.25	12.00	12.65	9.5
10.0		11.20	11.00	11.65	10.0
11.0		9.55	9.30	9.95	11.0
12.0		8.20	8.00	8.55	12.0
13.0		7.10	6.90	7.45	13.0
14.0		6.20	5.95	6.55	14.0
14.4		5.90	5.65	6.20	14.4
15.0			5.20	5.75	15.0
16.0			4.55	5.10	16.0
17.0			4.00	4.50	17.0
18.0			3.50	4.00	18.0
19.0			2.95	3.55	19.0
20.0			2.55	3.15	20.0
21.0			2.15	2.75	21.0
21.1			2.10	2.70	21.1
22.0				2.40	22.0
23.0				2.05	23.0
24.0				1.75	24.0
25.0				1.50	25.0
26.0				1.25	26.0
Max. boom angle	65.0°	75.6°	79.8°	82.1°	Max. boom angle
Min. boom angle	0°	0°	0°	22.4°	Min. boom angle

Ratings shown in   are determined by the strength of the boom or other structural components.

▶ Without counterweight (optional setting)

(Unit : metric ton)

Working radius (m) \ Boom length (m)	9.99	16.7	Boom length (m) \ Working radius (m)
3.0	30.00	20.00	3.0
3.5	30.00	20.00	3.5
3.7	30.00	20.00	3.7
4.0	30.00	20.00	4.0
4.5	30.00	20.00	4.5
5.0	24.50	20.00	5.0
5.5	20.45	20.00	5.5
6.0	17.45	17.05	6.0
6.5	15.10	14.75	6.5
7.0	13.25	12.90	7.0
7.5	11.75	11.35	7.5
7.7	11.20	10.80	7.7
8.0		10.10	8.0
8.5		9.05	8.5
9.0		8.10	9.0
9.5		7.35	9.5
10.0		6.65	10.0
11.0		5.50	11.0
12.0		4.60	12.0
13.0		3.85	13.0
14.0		3.25	14.0
14.4		3.05	14.4
Max. boom angle	65.0°	75.6°	Max. boom angle
Min. boom angle	0°	0°	Min. boom angle

► **WORKING RANGES** (Unit : m)

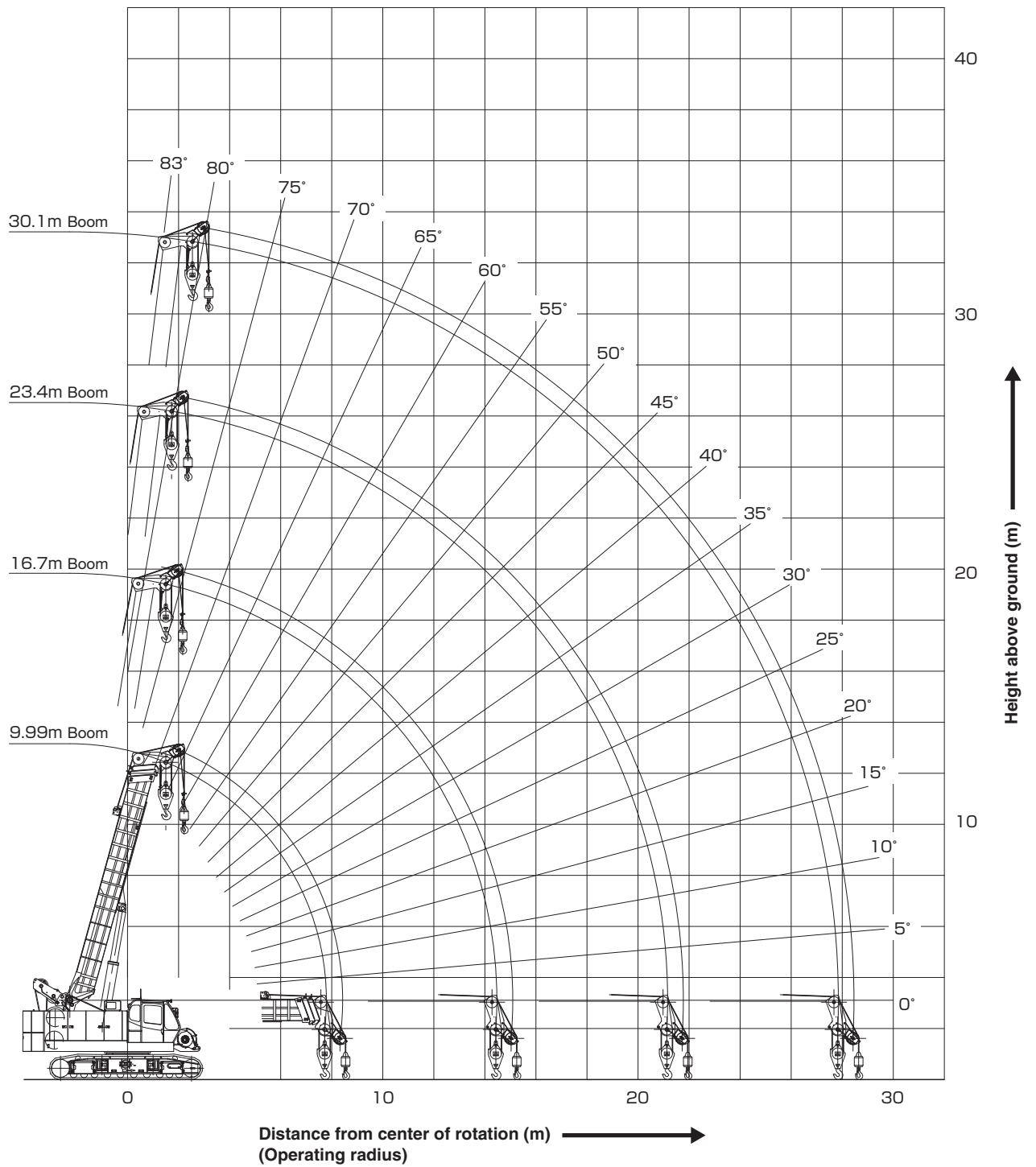

► **GENERAL DIMENSIONS** (Unit : mm)

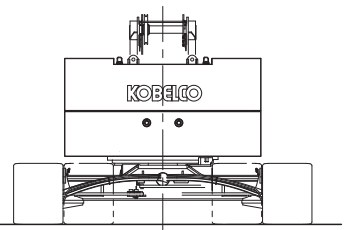
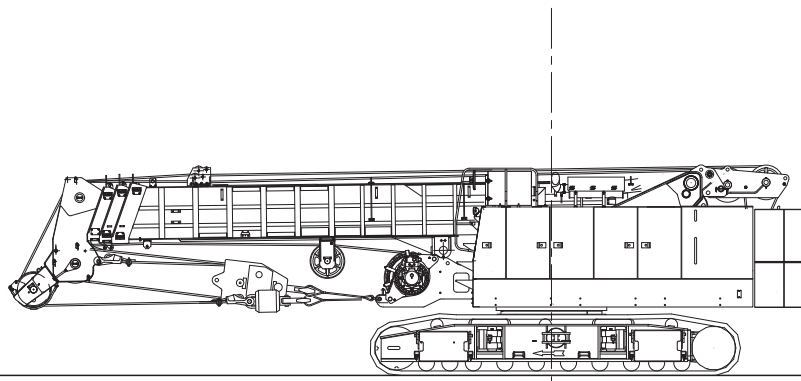
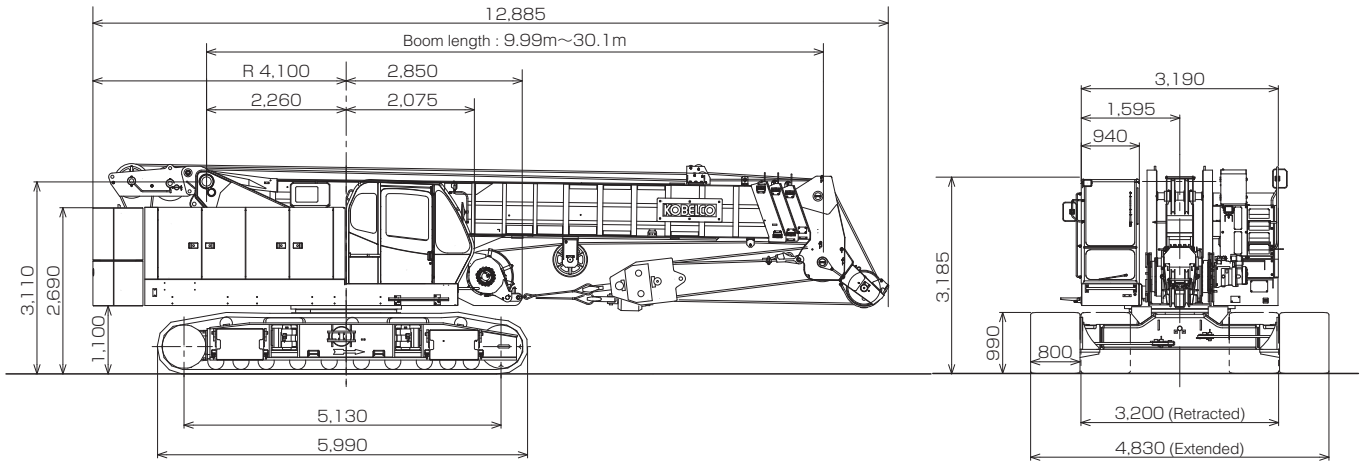
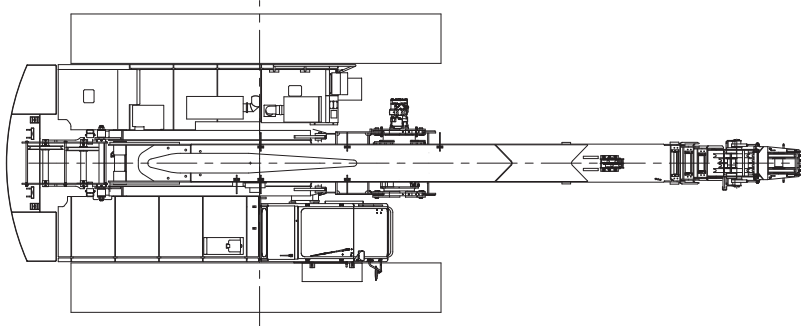

## ▶ STANDARD EQUIPMENT

Upper Structure/Lower Structure
Third drum : wire rope 26dia. x 125m, with free-fall
Counterweight : 17.2t (9.0t + 8.2t)
Crawlerweight : 2.0t (0.5t x 4)
800mm shoe crawlers
165G51 battery
Electric hand throttle grip
Variable main/aux. speed controller
Side deck (for cab) : 300mm (W) x 970mm (L)
Anti-slip sheet
Tools (for routine maintenance)
Lubrication device
Tool box (equipped on right-side guard)
Three front working lights
Two back mirrors
Cab
Air conditioner
Convenient compartment
Cup holder
AM/FM Radio
Ashtray
Cigarette lighter
Intermittent windshield wiper with window washer (roof, front and lower front window)
Sun visor
Roof blind
Tinted glass
Floor mat (cloth)
Foot pedal cover (rubber)
Shoe tray

Safety Device
Over-load prevention device (auto stop function)
Release prevention key for hook over-hoist prevention device
LCD Multi-display (shows gauges and warning signs)
Hook over-hoist auto-stop device
Operating zone limit device
Safety lever lock
Propel lever lock
Manual drum safety pawl (main, aux.)
Negative brake in lever neutral-position (main, aux., third, travel)
Brake fail safe mechanism (main, aux., third, travel)
Service brake pedal lock (main, aux.)
Lamp for neutral-free/brake select switch (main, aux.)
Neutral-free/brake select switch (main, aux.)
Neutral brake release prevention key (main, aux.)
Brake activating device for engine stop
Hydraulically safety valve
Boom telescoping default operation prevention device (Automatic)
Boom telescoping safety device
Boom hoist safety device
Over hook limit device
Sling wire lock
Horn
Swing lock pin
Swing flashers
Swing warning buzzer
Voice alarm for travel/swing (over hoist, over load, crawler extension)
Level gauge

## ▶ OPTIONAL EQUIPMENT

4-spool valve : Max. discharge pressure 17.2MPa{175kgf/cm <sup>2</sup> } Max. discharge flow 40liters/min
Outlet for Auger : Max. output 145kW{200PS} Max. discharge pressure 30.0MPa{305kgf/cm <sup>2</sup> } Max. discharge flow 425liters/min (with oil flow select switch)
Hydraulic tagline : 10dia. x 45m
Lifting capacity set : insert counterweight/without counterweight
Swing neutral brake : cannot select swing neutral free
11-ton light swivel ball hook : 100kg
Counterweight self-removal device
Trans-lifter
Foot acceleration : right hand

Boom hoist pedal : right hand (not available to equip with foot acceleration)
Engine rpm fix switch : 4-steps
Cab roof guard
Side catwalk (without handrail) : 300mm (W) x 3,710mm (L)-right hand/4,090mm (L)-left hand
Color monitoring camera (backward) with monitor
Monitoring camera for main/aux. with lightning
Overload alarm lamp (3 colors, square shape)
One way call
Electric fuel pump
Fire extinguisher
Electric fan

Note: This catalog may contain photographs of machines with specifications, attachments and optional equipment not certified for operation in your country. Please consult KOBELCO for those items you may require. Due to our policy of continual product improvements all designs and specifications are subject to change without advance notice.

Copyright by KOBELCO CRANES CO., LTD. No part of this catalog may be reproduced in any manner without notice.

## KOBELCO CRANES CO., LTD.

17-1, Higashigotanda 2-chome, Shinagawa-ku, Tokyo 141-8626 JAPAN

Tel: +81-3-5789-2130 Fax: +81-3-5789-3372

URL: <http://www.kobelco-cranes.com/>

Inquiries To: